



Doehler & Haass

Locomotive decoder

Locomotive function decoder

Locomotive decoder

DH05C	PD05A
DH10C	PD06A
DH12A	PD12A
DH14B	PD18A
DH16A	PD21A
DH18A	
DH21A	
DH22A	

Locomotive function decoder

FH05B
FH18A
FH22A



1	Introduction	4
2	Safety instructions	4
3	Warranty	4
4	Support and help.....	4
5	Locomotive decoder DH05C / DH10C / DH12A / DH14B / DH16A / DH18A / DH21A / DH22A / PD05A / PD06A / PD12A / PD18A / PD21A.....	5
5.1	Functions.....	16
5.2	Installation of the decoder.....	17
5.3	Connection of the decoder.....	18
5.4	Check after installation.....	20
6	Locomotive function decoder FH05B / FH18A / FH22A.....	21
6.1	Functions.....	24
6.2	Installation of the Locomotive function decoders	25
6.3	Connection of the Locomotive function decoders	25
6.4	Check after installation.....	28
7	System format SelecTRIX 1 (SX1)	28
7.1	Functions.....	28
7.2	Setting options	29
7.3	Operation.....	31
7.4	Explication of the brake sections.....	31

8	System format DCC	32
8.1	Functions	32
8.2	Setting options	33
8.2.1	List of supported CV	34
8.3	Operation	48
9	System format Märklin-Motorola (MM)	48
9.1	Functions	48
9.2	Programming with Märklin central unit 6020/6021	49
10	System format SelecTRIX 2 (SX2)	52
10.1	Functions	52
10.2	Setting options	52
10.2.1	List of supported parameters	53
10.3	Operation	65
	Supplement 1: Notes to Function Mapping	66
	Supplement 2: Speed characteristics	68
	Supplement 3: Unamplified function outputs AUX3 ... AUX6	69
	Supplement 4: Electric coupling / Freewheeling diode	69
	Supplement 5: Automatic coupling procedure (“coupling waltz”)	71
	Supplement 6: Decoder recognition (type and firmware version)	74

1 Introduction

The locomotive decoders DH05C, DH10C, DH12A, DH14B, DH16A, DH18A, DH21A, DH22A and PD05A, and also the locomotive function decoders FH05B, FH18A and FH22A are compatible with the protocols of SelecTRIX standard SX1 and SX2, as well as with NMRA DCC and MM1/MM2 standard. They can be operated by every central unit supporting one of these system formats. The locomotive decoder PD12A, PD18A und PD21A supports only DCC and DC analog. All decoders can be used for normal direct current motors as well for coreless motors.

The operation on alternating current supplied layouts with switching impulse is not allowed!

The switching impulse destroys the decoder!

Exception: DH21A and DH22A

2 Safety instructions

This product is not suitable for children under 14 years.

It might be swallowed by children under 3 years!

An improper use involves a risk of injury due to sharp edges and points.

3 Warranty

The functioning of every decoder is fully tested before delivery. Should nevertheless a failure occur, please contact the dealer where you purchased the decoder or directly the producer (Doehler & Haass enterprises). The warranty period is two years from the data of purchase.

4 Support and help

In case you have any problems or questions please contact us by email technik@doehler-haass.de

Usually you will get an answer within a few days.

5 Locomotive decoder DH05C/10C/12A/14B/16A/18A/21A/22A/PD05A/PD06A/PD12A/PD18A/PD21A

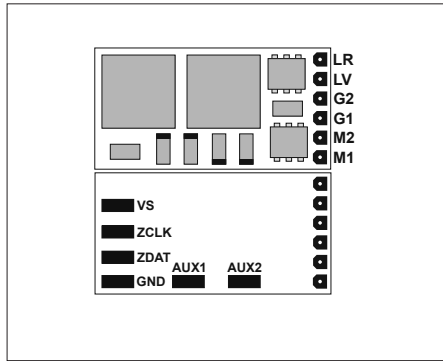
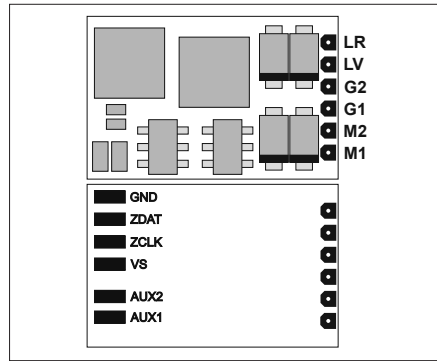
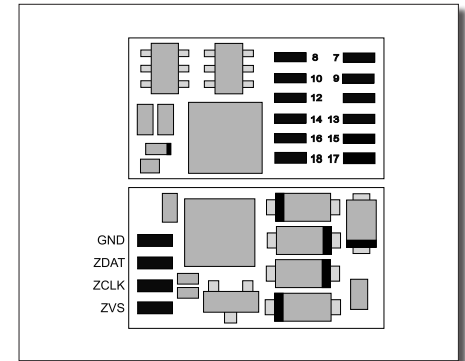
DH05C

DH10C

DH12A

- M1, M2** Motor connection 1, 2
- G1, G2** Track connection 1, 2
- LV** Front light
- LR** Rear light
- AUX1...AUX4** Additional function 1...4

- VS** Supply voltage (also for SUSI)
- ZVS** SUSI supply voltage
- ZCLK** SUSI clock (or AUX3 unamplified or AUX5 unamplified) *)
- ZDAT** SUSI data (or AUX4 unamplified or AUX6 unamplified) *)
- GND** SUSI ground

*) Unamplified function outputs: see supplement 3

PluX12 interface

	1	2	
	3	4	
	5	6	
LV	7	8	M1
VS	9	10	M2
Index	11	12	G1
LR	13	14	G2
*) AUX3	15	16	AUX1
*) AUX4	17	18	AUX2
	19	20	
	21	22	

Specifications	DH05C	DH10C	DH12A
Dimensions [mm]	13,2 x 6,8 x 1,4	14,2 x 9,3 x 1,5	14,5 x 8,0 x 3,0
Total load	0,5 A	1,0 A	1,5 A
Maximum motor current	0,5 A	1,0 A	1,5 A
Maximum operating voltage	18 V	30 V	30 V
Function outputs for light: LV, LR (dimmmable)	each 150 mA	each 150 mA	each 150 mA
Function outputs: AUX1, AUX2 (dimmmable)	each 300 mA	each 300 mA	each 300 mA
Function outputs: AUX3, AUX4	unamplified *)	unamplified *)	unamplified *)
Function outputs: AUX5, AUX6			unamplified *)
With SUSI interface (if AUX3/AUX4 deactivated)	X	X	
With SUSI interface (if AUX5/AUX6 deactivated)			X
Connecting options			
Without connection wires	DH05C-0	DH10C-0	
With ribbon cable for standard plug NEM651	DH05C-1	DH10C-1	
With connection wires	DH05C-3	DH10C-3	
12 pin connector for direct plugging (PluX12)			DH12A

*) Unamplified function outputs: see supplement 3

DH14B

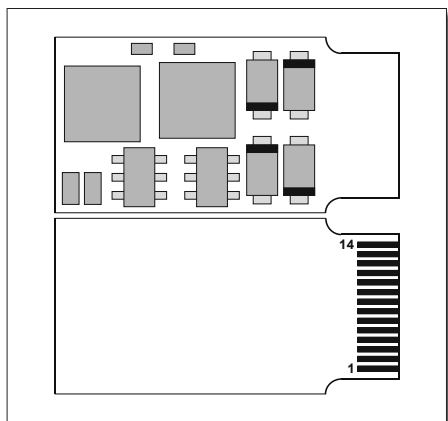

Specifications	DH014B
Dimensions [mm]	18,5 x 9,2 x 1,7
Total load	1,0 A
Maximum motor current	1,0 A
Maximum operating voltage	30 V
Function outputs for light: LV, LR (dimnable)	each 150 mA
Function outputs: AUX1, AUX2 (dimnable)	each 300 mA
Function outputs: AUX3, AUX4	unamplified *)
With SUSI interface (if AUX3/AUX4 deactivated)	
Connecting options	DH14B
14 pole foil plug for direct plugging (mTc14)	DH14B

*) Unamplified function outputs: see supplement 3

DH16A

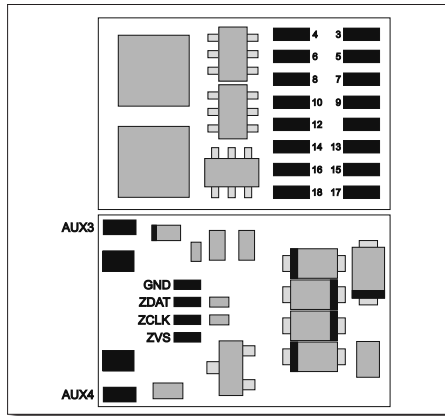

DH18A

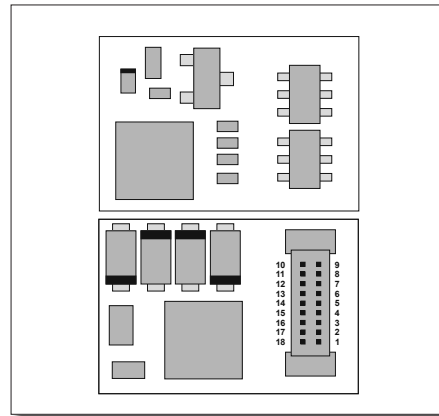

DH21A

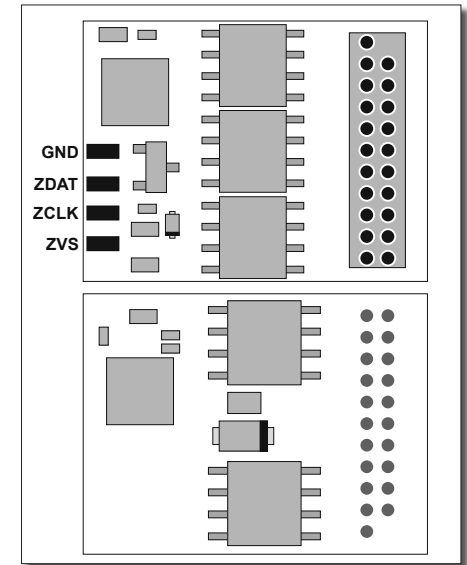

PluX16 interface

--	1	2	AUX3
ZCLK	3	4	ZDAT
GND	5	6	VS
LV	7	8	M1
VS	9	10	M2
Index	11	12	G1
LR	13	14	G2
--	15	16	AUX1
--	17	18	AUX2
AUX4	19	20	AUX5
AUX6	21	22	AUX7

21 pin interface

GPIO	1	22	G1
--	2	21	G2
--	3	20	GND
AUX4	4	19	M1
ZCLK	5	18	M2
ZDAT	6	17	--
LR	7	16	VS
LV	8	15	AUX1
--	9	14	AUX2
--	10	13	AUX3
Index	11	12	VCC

Specifications	DH16A	DH18A	DH21A
Dimensions [mm]	16,7 x 10,9 x 2,8	13,5 x 9,0 x 2,8	20,7 x 15,8 x 5,2
Total load	1,5 A	1,0 A	2,0 A
Maximum motor current	1,5 A	1,0 A	2,0 A
Maximum operating voltage	30 V	30 V	30 V
Switching voltage at AC analog: Max. 45 V peak = 30 V eff.	n.a.	n.a.	X
Function outputs for light: LV, LR (dimnable)	each 150 mA	each 150 mA	each 150 mA
Function outputs: AUX1, AUX2 (dimnable)	each 300 mA	each 300 mA	each 300 mA
Function outputs: AUX3, AUX4	each 1,0 A	unamplified **)	each 1,0 A *) or unamplified *) **)
Function outputs: AUX5, AUX6	unamplified **)	unamplified **)	unamplified **)
With SUSI interface (if AUX3/AUX4 deactivated)		X	
With SUSI interface (if AUX5/AUX6 deactivated)	X		X
Connecting options			
Without connection wires	DH16A-0		DH21A-0
With connection cable for interface per NEM652	DH16A-2		DH21A-2
With connection wires	DH16A-3		DH21A-3
16 pin connector for direct plugging (PluX16)	DH16A-4		
18 pin connector for direct plugging (Next18)		DH18A	
21 pin socket board for direct plugging (mTc21)			DH21A-4 I -5 *)

*) DH21A is available in two different HW versions:

- Function outputs AUX3, AUX4: each 1,0 A (connection version -4)
- Function outputs AUX3, AUX4: unamplified (connection version -5)

***) Unamplified function outputs: see supplement 3

DH22A

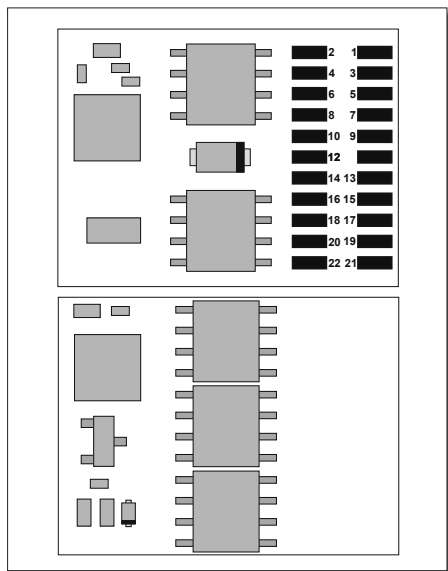

Specifications

Dimensions [mm]
 Total load
 Maximum motor current
 Maximum operating voltage
 Switching voltage at AC analog:
 Max. 45 V peak = 30 V eff.
 Function outputs for light: LV, LR (dimnable)
 Function outputs: AUX1, AUX2 (dimnable)
 Function outputs: AUX3, AUX4
 Function outputs: AUX5, AUX6
 With SUSI interface (if AUX5/AUX6 deactivated)

DH22A

20,7 x 15,8 x 5,2
 2,0 A
 2,0 A
 30 V
 each 150 mA
 each 300 mA
 each 1,0 A
 unamplified *)

Connecting options

22 pin connector for direct plugging (PluX22)

DH22A-4

*) Unamplified Function outputs:
 see supplement 3

PluX22 interface

--	1	2	AUX3
ZCLK	3	4	ZDAT
GND	5	6	ZVS
LV	7	8	M1
VS	9	10	M2
Index	11	12	G1
LR	13	14	G2
--	15	16	AUX1
--	17	18	AUX2
AUX4	19	20	AUX5
AUX6	21	22	AUX7

PD05A

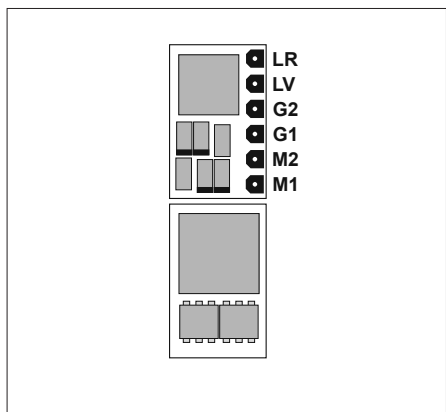

Specifications	PD05A
Dimensions [mm]	5,0 x 7,9 x 2,5
Total load	0,5 A
Maximum motor current	0,5 A
Maximum operating voltage	18 V
Function outputs for light: LV, LR (dimnable)	each 150 mA
Connecting options	
Without connection wires	PD05A-0
With ribbon cable for standard plug NEM651	PD05A-1
With connection wires	PD05A-3

Notice:

The Nano locomotive decoder PD05A is a locomotive decoder for SX1, SX2 and DCC operation. There are following limitations compared to our DH decoder series:

- No support of operating mode MM and DC analog
- No support of SX1 programming (but SX1 operation is possible by SX2 parameter programming)
- No SUSI interface and no function outputs
- No extended function mappings (i.e. no conditions, no initial mapping etc.)
- No automatic coupling process
- No brake ramp

PD06A

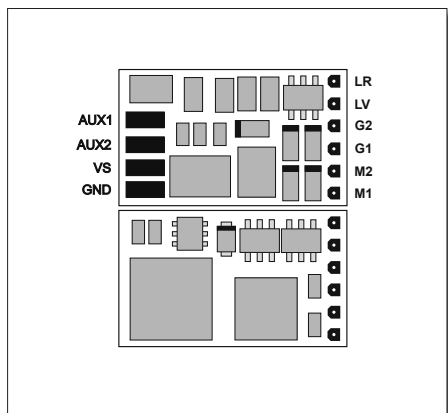

Specifications

Dimensions [mm]
 Total load
 Motor voltage
 Maximum motor current
 Maximum operating voltage
 Function outputs for light: LV, LR (dimnable)
 Function outputs: AUX1, AUX2 (dimnable)

PD06A

6,8 x 11,4 x 2,8
 0,5 A
 6 V
 0,2 A
18 V
 each 150 mA
 each 300 mA

Connecting options

Without connection wires
 With connection wires

PD06A-0
 PD06A-3

Notice:

The PD06A locomotive decoder for miniature engines is our new, particularly small vehicle decoder for the SX1, SX2 and DCC operation. There are following limitations compared to our DH decoder series:

- No support of operating mode MM
- No support of SX1 programming (but SX1 operation is possible by SX2 parameter programming)
- No SUSI interface
- No extended function mappings (i.e. no conditions, no initial mapping etc.)
- No automatic coupling process
- No braking with asymmetrical digital voltage and no slow driving
- No brake ramp

PD12A

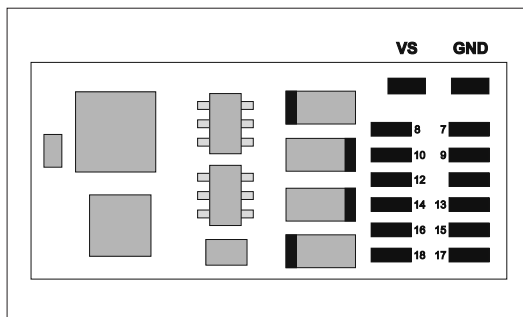

PluX12-Interface

	1	2	
	3	4	
	5	6	
LV	7	8	M1
VS	9	10	M2
Index	11	12	G1
LR	13	14	G2
--	15	16	AUX1
--	17	18	AUX2
	19	20	
	21	22	

Specifications

PD12A

Dimensions [mm]	24,2 x 11,0 x 2,4
Total load	1,0 A
Maximum motor current	1,0 A
Maximum operating voltage	30 V
Function outputs for light: LV, LR (dimnable)	each 150 mA
Function outputs: AUX1, AUX2 (dimnable)	each 300 mA

Connecting options

Without connection wires	PD12A-0
With connection cable for interface per NEM652	PD12A-2
With connection wires	PD12A-3
12 pin connector for direct plugging (PluX12)	PD12A-4

Notice:

PD12A is a locomotive decoder for DCC operation only (and DC analog). There are following limitations compared to our DH decoder series:

- No support of operating mode SX1, SX2 and MM
- No SUSI interface and no unamplified function outputs
- No extended function mapping (i.e. no conditions, no initial mapping etc)
- No automatic coupling process (Timer for switching off AUX1 and AUX2 are however available)

PD18A

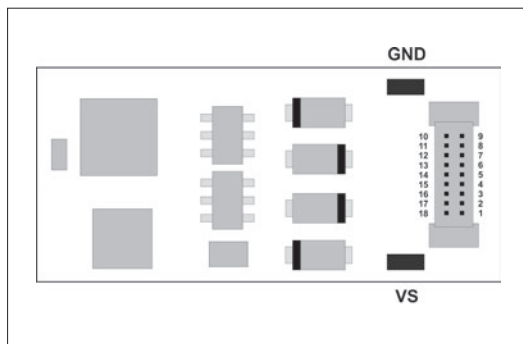

Specifications

Specifications	PD18A
Dimensions [mm]	23,8 x 10,8 x 2,0
Total load	1,0 A
Maximum motor current	1,0 A
Maximum operating voltage	30 V
Function outputs for light: LV, LR (dimnable)	je 150 mA
Function outputs: AUX1, AUX2 (dimnable)	je 300 mA

Connecting options

18 pin connector for direct plugging (Next18)	PD18A
---	-------

Notice:

PD18A is a locomotive decoder for DCC operation only (and DC analog). There are following limitations compared to our DH decoder series:

- No support of operating mode SX1, SX2 and MM
- No SUSI interface and no unamplified function outputs
- No extended function mapping
(i.e. no conditions, no initial mapping etc)
- No automatic coupling process
(Timer for switching off AUX1 and AUX2 are however available)

PD21A

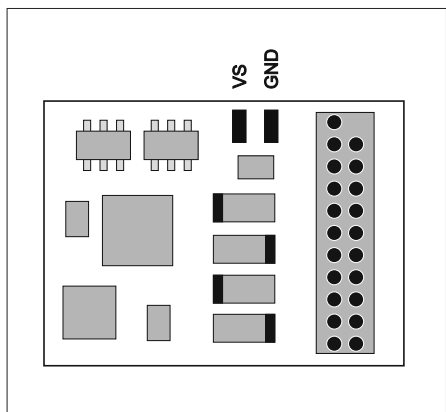

Specifications	PD21A
Dimensions [mm]	21,2 x 15,5 x 2,9
Total load	1 A
Maximum motor current	1 A
Maximum operating voltage	30 V
Function outputs for light: LV, LR (dimnable)	each 150 mA
Connecting options	
21 pin socket board for direct plugging (mTc21)	PD21A-4

Notice:

The PD21A locomotive decoder is our new, particularly low priced, locomotive decoder for pure DCC operation (and DC analog). There are only

some minor limitations compared to our DH decoder series:

- No support of operating mode SX1, SX2 and MM
- No SUSI interface and no unamplified function outputs
- No extended function mappings (i.e. no conditions, no initial mapping etc.)
- No automatic clutch release (but timers for switching off AUX1 and AUX2 are available)

5.1 Functions

- Operation can be controlled either by conventional DC command stations or by digital central units supporting the formats SelecTRIX 1 and 2, NMRA standard (DCC) or MM1/MM2 standard
(PD05A: no MM, no DC analog, PD06A: no MM, PD12A, PD18A, PD21A: only DCC, DC analog)
- Automatic switch over from conventional DC to digital operation
- In case of digital operation the last programmed system will be activated. Automatic switching into a certain operating mode is not possible because of the multiprotocol operation. For switching a parameter (e.g. locomotive address) is to be readout and must be written again in the required operating mode. Thus the switching to the required track protocol is completed.
- SelecTRIX 1 31 speed steps, 100 addresses
- SelecTRIX 2 127 speed steps, 10.000 addresses, 16 additional functions
- DCC short addresses (1-127), long addresses (0001-9999), with 14, 28, 126 speed steps
- State of art load regulation, in this way an especially smooth control mode
- Different control variants for an optimal adaption to the motor
- 127 internal speed steps
- Adjustable motor frequency (low frequency, 16 kHz, 32 kHz)
- Block section operation by simple diodes in digital operation
- Light and function outputs are (partly) dimmable and can be activated analogously
- Shunting gear
- Motor, light and track connections electronically changeable
- All function outputs are freely programmable
- Thermal protection
- Reset function for DCC and SX2

- The decoder can be updated (Programmer required):
Updating can be executed on the incorporated decoder when the locomotive is standing on track (no need to open the engine, free SW download from the internet)
- Decoders support braking with asymmetric digital voltage (four diodes connected in series and one antiparallel diode), slow approach (with appropriate brake modules) and the bidirectional communication (locomotive address check back signal in DCC operation, RailCom®).

5.2 Installation of the decoder

Before installation check if the locomotive is in perfect electrical and mechanical condition. Defects and dirt must be eliminated first. Pay attention to the instructions of the locomotive producer.

Only locomotives running smoothly in analogue mode should be equipped with digital decoder. New locomotives should be run in at least 30 minutes in each driving direction.

Before starting installation, insulate the motor and all its terminals completely against track connections (sliders, chassis etc.).

Both motor connections must be disconnected from the ground!

Further on all capacitors have to be removed, particularly those associated with the connections of light and motor.

Fix the decoder with a double sided adhesive tape.

5.3 Connection of the decoder

There are following variants to connect the decoder:

- 1 In case your locomotive is equipped with an interface according to NEM 651, you should take the decoder **DH05C-1** or **DH10C-1** or **PD05A-1**. They have already the appropriate connections for this plug. Short the ribbon cable up to 5 mm and remove the rest of insulation. The decoder can be inserted into the interface without any problem now.
- 2 In case your locomotive is equipped with an interface according to NEM 652, you should take the decoder **DH16A-2**, **DH21A-2** or **PD12A-2**. They have already the appropriate connections for this plug with an 8 pin plug. The decoder can be inserted into the interface without any problem now.
- 3 In case your locomotive is equipped with a 12 pin interface (PluX12), you should take the decoder **DH12A** or **PD12A-4**. They have already the appropriate connections for this plug. The decoder can be inserted into the interface without any problem now.
- 4 In case your locomotive is equipped with a 14 pin interface (mTc14), you should take the decoder **DH14B**. It has already the appropriate connection for this plug. The decoder can be inserted into the interface without any problem now.
- 5 In case your locomotive is equipped with a 16 pin interface (PluX16), you should take the decoder **DH16A-4**. It has already the appropriate connection for this plug. The decoder can be inserted into the interface without any problem now.
- 6 In case your locomotive is equipped with an 18 interface (Next18), you should take the decoder **DH18A** or **PD18A**. It has already the appropriate connection for this plug. The decoder can be inserted into the interface without any problem now.
- 7 In case your locomotive is equipped with a 21 pin interface, you should take the decoder **DH21A-4** or **PD21A-4**. It has already the appropriate connection for this plug. The decoder can be inserted into the interface without any problem now.
- 8 In case your locomotive is equipped with a 22 pin interface (PluX22), you should take the decoder **DH22A-4**. It has already the appropriate connection for this plug. The decoder can be inserted into the interface without any problem now.
- 9 In case your locomotive is not equipped with an interface jack, the decoders must be wired individually. For this purpose you should use the decoders with flexible wires (**DH05C-3**, **DH10C-3**, **DH16A-3**, **DH21A-3**, **PD05A-3**, **PD06A-3**, **PD12A-3**).
- 10 The decoders **DH05C-0**, **DH10C-0**, **DH16A-0**, **DH21A-0**, **PD05A-0**, **PD06A-0** and **PD12A-0**, should be used by experienced model railroaders only, as the connection wires must be soldered directly onto the decoder.

For above variant 9 connect the decoder wires according to the following diagram (see also the chart below):

- red wire with the right track wire
- black wire with the left track wire
- orange wire..... with the motor wire, which was connected to the right track wire
- gray wire..... with the motor wire, which was connected to the left track wire
- white wire..... with the front light in driving direction
- yellow wire with the rear light in driving direction
- green wire function output AUX1 (only DH16A-**2/3** and DH21A-**2/3**)
- violet wire..... function output AUX2 (only DH16A-**3** and DH21A-**3**)
- blue wire..... common return, can carry up to 30 volts (+VS) (only DH16A-**2/3** and DH21A-**2/3**)

The wires of an additionally connected SUSI module are connected according to the following scheme:

- red wire SUSI supply voltage (ZVS)
- blue wire..... SUSI clock (ZCLK)
- gray wire..... SUSI data (ZDAT)
- black wire SUSI ground (GND)

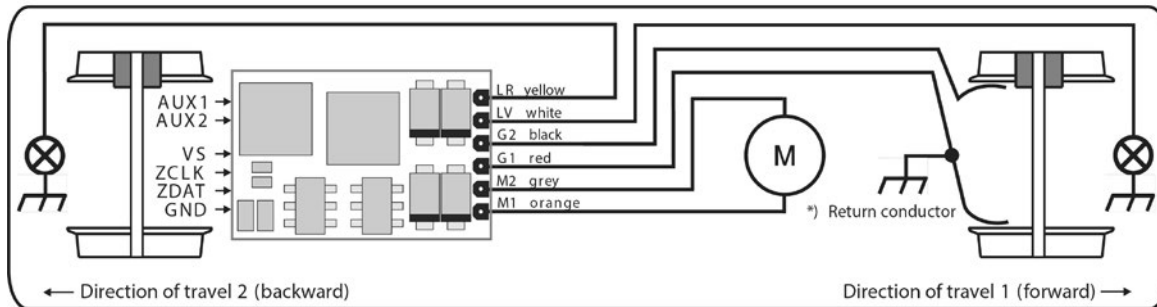

*) Depending on the manufacturer, the return conductor can be connected to wheel 1 or 2 (red or black) and to the locomotive chassis

Function outputs:

The function outputs AUX1, AUX2 (amplified, only if available) and AUX3, AUX4 (unamplified, only if available) are possibly on the underside of the decoder and must be connected to the consumer with individual wires or – if unamplified – via appropriate amplifiers.

Notice:

In case of an incorrect wiring of motor, lighting and track, there is no need to solder off the wires as the assignment can be interchanged electronically by programming (see setting options of the respective system format: CV51 or par031, par032, par033).

5.4 Check after installation

The first test should be made in programming mode (e.g. by reading out the address). If there is not correct check back signal to the central unit ("Error"), check again the mapping of the connection or the electrical separation of the motor from the chassis.

6 Locomotive function decoder FH05B / FH18A / FH22A

FH05B

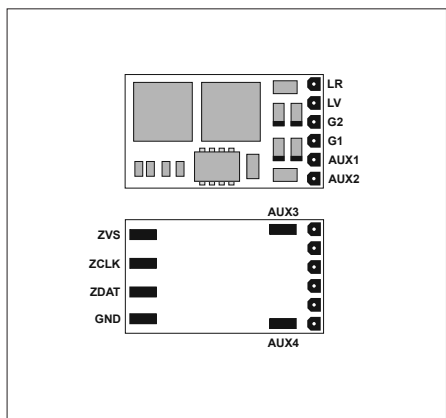

G1, G2 Track connection 1, 2
LV Front light
LR Rear light
AUX1...AUX6 Additional function 1...6

ZVS SUSI supply voltage
ZCLK SUSI clock
ZDAT SUSI data
GND SUSI ground

Specifications

Dimensions [mm]
 Total load
 Maximum operating voltage
 Function outputs for light: LV, LR (dimnable)
 Function outputs AUX1, AUX2 (dimnable)
 Function outputs AUX3, AUX4
 Function outputs AUX5, AUX6
 With SUSI interface (if AUX5/AUX6 deactivated)

FH05B

13,7 x 7,8 x 1,5
 0,5 A
 30 V
 each 150 mA
 each 300 mA
 unamplified *)
 unamplified *)

Connecting options

Without connection wires
 With ribbon cable for standard plug NEM651
 With connection wires

FH05B-0
 FH05B-1
 FH05B-3

*) Unamplified function outputs: see supplement 3

FH18A

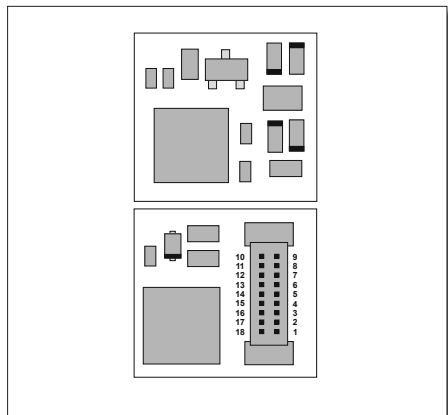

Specifications

Dimensions [mm]
 Total load
 Maximum operating voltage
 LV, LR (dimmbable)
 AUX1, AUX2 (dimmbable)
 AUX3, AUX4
 AUX5, AUX6
 With SUSI interface (if AUX3/AUX4 deactivated)

FH18A

10,4 x 9,7 x 3,2
 1,0 A
 30 V
 each 150 mA
 each 300 mA
 unamplified *)
 unamplified *)

Connecting options

18 pin connector for direct plugging (Next18)

FH18A

*) Unamplified function outputs: see supplement 3

FH22A

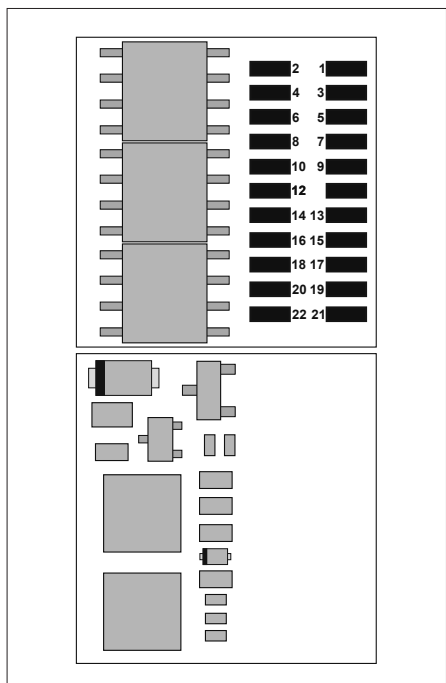

Specifications

Dimensions [mm]

Total load

Maximum operating voltage

Switching voltage at AC analog:

Max. 45 V peak = 30 V eff.

LV, LR (dimnable)

AUX1, AUX2 (dimnable)

AUX3, AUX4

AUX5, AUX6

With SUSI interface (if AUX5/AUX6 deactivated)

FH22A

16,1 x 15,8 x 3,3

2,0 A

30 V

each 150 mA

each 300 mA

each 1,0 A

unamplified *)

Connecting options

22 pin connector for direct plugging (PluX22)

FH22A-4

*) Unamplified function outputs: see supplement 3

PluX22 interface

--	1	2	AUX3
ZCLK	3	4	ZDAT
GND	5	6	ZVS
LV	7	8	--
VS	9	10	--
Index	11	12	G1
LR	13	14	G2
--	15	16	AUX1
--	17	18	AUX2
AUX4	19	20	AUX5
AUX6	21	22	AUX7

6.1 Functions

- Operation can be controlled either by conventional DC command stations or by digital central units supporting the formats SelectRIX 1 and 2, NMRA standard (DCC) or MM1/MM2 standard.
- Automatic switchover from conventional DC to digital operation.
- In case of digital operation the last programmed system will be activated. Automatic switching into a certain operating mode is not possible because of the multi protocol operation. For switching a parameter (e.g. the locomotive address) is to be readout and must be written again in the required operating mode. Thus the switching to the required track protocol is completed.
- SelectRIX 1 31 speed steps, 100 addresses
- SelectRIX 2 127 speed steps, 10.000 addresses, 16 additional functions
- DCC short addresses (1-127), long addresses (0001-9999), with 14, 28, 126 speed steps
- 127 internal speed steps
- Block section operation by simple diodes in digital operation
- Light and function outputs are (partly) dimmable and can be activated analogously
- Shuntig gear
- Light and track connections are electronical changeable
- All function outputs are freely programmable
- Thermal protection
- Reset function for DCC and SX2
- The decoder can be updated:
The update can be executed on the incorporated decoder when the locomotive is standing on track (no need to open the engine, free SW download from the internet)
- **FH05B, FH18A** and **FH22A** support braking system with asymmetric digital voltage (four diodes connected in series and one antiparallel diode), slow approach (with appropriate brake modules) and the bidirectional communication (locomotive address check back signal in DCC operation, RailCom®).

FH05B, **FH18A** and **FH22A** correspond functionally completely with the decoders described in point 5. Only features in direct connection with the engine control are missing. This fact is marked in the setting options of the corresponding system format. See:

- Point 7.2
- Point 8.2: CV09, CV49, CV50, CV51/Bit 0, CV56 – CV59, CV112
- Point 10.2: par017, par032, par052 – par054, par056 – par059

6.2 Installation of the locomotive function decoder

See notice in point 5.2

6.3 Connection of the locomotive function decoder

There are following variants to connect the locomotive function decoder **FH05B**:

- 1 In case your locomotive is equipped with an interface according to NEM 651, use decoder **FH05B-1**. It has already the appropriate connections for this plug. Short the ribbon cable up to approximately 5 mm and remove the rest of the insulation. The decoder can be inserted into the interface without any problem now.

Attention:

The additional functions AUX1 and AUX2 are issued to those interface lines at which in locomotive decoders the motor is connected. Therefore **FH05B-1** should not be installed in a 6 pin interface of a locomotive with engine.

- 2 In case your locomotive has no interface socket, use decoder **FH05B-3** and wire it individually.
- 3 Decoder **FH05B-0** should be used only by experienced model railroaders, as the connection wires must be soldered directly onto the decoder.

There are following variants for the connection of the locomotive function decoder **FH18A**:

- 4 In case your locomotive is equipped with an interface according to NEM 651, you need for **FH18A** the connecting adapter **N18-K-1**. It has already the appropriate connections for this plug. Short the ribbon cable up to approximately 5 mm and remove the rest of the insulation. The decoder can be inserted into the interface without any problem now.

- 5 In case your locomotive is equipped with an interface according to NEM 652, you need for FH18A the connecting adapter **N18-G-2**. It has already the appropriate connection cables for this socket with an 8 pin plug. The decoder can be inserted into the interface without any problem now.
- 6 In case your locomotive is equipped with an 18 pin interface (Next18), you can plug FH18A directly into the interface without any problem.
- 7 In case your locomotive has no interface socket, you need for FH18A either connecting adapter **N18-K-3** without SUSI) or **N18-G-3** ((with SUSI) for an individual wiring.
- 8 Connecting adapter **N18-K-0** (without SUSI) or **N18-G-0** (with SUSI) should be used only by experienced model railroaders, as the connection wires must be soldered directly onto the respective adapter

There are following variants to connect the locomotive function decoder **FH22A**:

- 9 In case your locomotive is equipped with a 22 pin interface (PluX22), use decoder FH22A-**4**. It has already the appropriate plug for this socket. The decoder can be inserted into the interface without any problem now.
- 10 In case your locomotive has no interface socket, use decoder FH22A-**4** together with the adapter P22-**3** for individual wiring.
- 11 Decoder FH22A-**4** together with the adapter P22-**0** should be used only by experienced model railroaders, as the connection wires must be soldered directly onto the adapter.

For above variants 2, 7 and 10 connect the decoder or adapter wires according to the following diagram (see also the chart on the following page):

red wire with the right track wire
 black wire with the left track wire
 white wire..... with the front light in driving direction
 yellow wire with the rear light in driving direction
 green wire function output AUX1
 violet wire function output AUX2

The connections of the SUSI interface for the sound or function modules are at FH05B on the underside of the decoder, at FH18A on the adapter N18-G and at FH22A-4 on the PluX22 plug respectively on the adapter P22-3. Connect these modules according to the following diagram:

red wire SUSI supply voltage (ZVS)
 blue wire SUSI clock (ZCLK)
 gray wire SUSI data (ZDAT)
 black wire SUSI ground (GND)

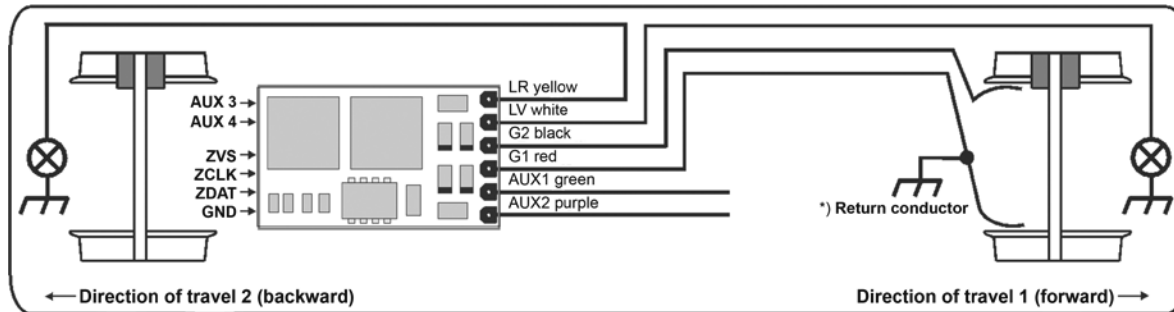

*) Depending on the manufacturer, the return conductor can be connected to wheel 1 or 2 (red or black) and to the locomotive chassis

Function outputs:

The unamplified function outputs AUX3 and AUX4 are at the underside of the decoder FH05B. They must be connected with the consumers via separate wires and via appropriate amplifiers.

Notice:

In case of an incorrect wiring of the light or track wire, there is no need to solder off the wires, as the assignment can be interchanged electronically by programming (see setting options of the respective system format: CV51 or. par031, par033).

6.4 Check after installation

See notice in point 5.4.

7 System formate SelecTRIX 1 (SX1)**7.1 Functions**

Speed steps.....	31
Speed steps (internal).....	127
Front lighth/rear light	yes
Additional functions	2
Functions in additional channel.....	8 (connectable with locomotive address + 1)
Operation with brake diodes	yes
Locomotive number output	yes

7.2 Setting options

All locomotive parameters can be varied by programming freely at any time. Please take the programming informations out of the instructions of your programming device.

Instructions for "Function Mapping" by default see Doehler & Haass website:

<https://doehler-haass.de/cms/pages/haeufige-fragen.php>:

Wie sieht das standardmäßige „Function Mapping“ aus? (only in German)

Basic settings

Locomotive address	01 ... 111	(01)	
Maximum speed.....	1 ... 7	(5)	1 = slow ... 7 = fast
Acceleration/Deceleration.....	1 ... 7	(3)	1 = low 7 = high
Impulse width (duration).....	1 ... 4	(2)	Not relevant to FH05B/FH18A/FH22A
Brake sections	1 / 2 part	(1)	

Extended settings

Interchange of connections	(V)	0 ... 7	(4)
Activation of AFB and additional channel	(A)	1 ... 7	(1)
Motor control variant	(I)	1 ... 4	(3)
Interchange of connections		0 ... 7	(4)
Interchange motor connections	1		Not relevant to FH05B/FH18A/FH22A
Interchange light connections	2		
Interchange track connections	4		

Activation of AFB (Automatic acceleration/deceleration control) and additional channel

Function	with AFB	without AFB
Without additional channel	1	2
With ZK*) without function mapping	3	4
With ZK*) with function mapping	5	6
Without ZK*) with function mapping	7	–

*) The additional channel (ZK) has always the address: Locomotive address + 1

Motor control variant	1 ... 4	Not relevant to FH05B/FH18A/FH22A
Setting by par056 ff.....	1	Hard..... 2
Soft.....	3	Very soft..... 4

Reading out the extended characteristic values is executed by the entry of the character sequence **00–111** and by pressing the programming key.

Writing of the extended characteristic values is executed by the entry of the character sequence **00=VAI** and by pressing the programming key.

Notice:

Coreless motors should be operated with regulation variant 4 and pulse width 1.

No warranty for damages due to incorrect adjustments.

Caution!

Reading out and entering extended characteristic values overwrite the default values of the decoder. In case you have varied the extended characteristic values; the default characteristic value of the decoder must be entered again.

Advice for decoder DH05C, DH10C, DH14B, DH18A, DH21A and FH18A:

For SX1 programming a connected SUSI sound module must be removed. It is sufficient to interrupt the supply voltage (red wire) during the time of SX1 programming. SX2 respective DCC programming and D&H sound modules are not concerned.

Decoder **DH12A, DH16A, DH22A, FH05B** and **FH22A** support SX1 programming also by connected SUSI sound module (ZVS available!). This only applies to **DH21A** if the SUSI interface will be connected over the soldered pads onto the decoder!

7.3 Operation

Put the locomotive on the programming track and readout the programming parameters of the decoder. The default value should be 01-532. Program the desired locomotive address and start running the locomotive with those parameter values. After the first check you can vary the parameters of the engine freels to your requirements.

In case your programming device indicates "Error", please check again the correct wiring of the locomotive and pay attention to the wiring instructions for connecting the programming track. **Never put such a locomotive into operation!**

7.4 Explanation of the brake sections

1 part brake section:

In front of the signal section one track is controlled by a diode. The decoder must be programmed on 1 part brake section (-). The locomotive decelerates to stop.

2 part brake section:

In front of the signal there are two track sections. The first one is controlled by a diode. The locomotive decelerates to internal speed step 3 in this section. The second one is without supply, thus the locomotive stops just in front of the signal. In this case the decoder must be programmed on 2 part brake section (=).

8 System format DCC

8.1 Functions

Short address	1-27
Long address	0001-9999
Speed steps.....	14, 28,126
Speed steps (internal).....	127
Front light/rear light (dimmmable).....	yes
Additional functions (dimmmable)	2
Functions total.....	28
Operation with brake diodes	yes
Operation with brake generators.....	yes
Consist mode	yes
Programming On The Main	yes
Locomotive number output.....	yes

Notice to address range:

DCC operation allows only address values from 1 to 127 for DCC-CV01, operating MM values from 1 to 255 are allowed. Values from 128 on lead to restricting the decoder operation only to MM, i.e. DCC operation is no longer possible. DCC "service mode" is of course still possible.

Activating the long DCC address through CV29/Bit5 makes vice versa that the decoder can be operated by DCC just now. MM operation is no longer possible then. MM programming is also disabled. Attention "lock out" is possible.

8.2 Setting options

The features of a locomotive operated in the DCC operating mode can be varied by programming the “Configuration Variables” (CV) freely at any time. The programming procedure is described in the instructions of your programming device.

Instructions for “Function Mapping” by default see Doehler & Haass website:

<https://doehler-haass.de/cms/pages/haeufige-fragen.php>:

Wie sieht das standardmäßige „Function Mapping“ aus? (only in German)

Notice:

In case the speed steps programmed on the decoder differ from those of the control device, malfunctions may occur. Please pay attention to the information concerning your digital system.

8.2.1 List of supported CV

The abbreviation **FH*** refers to the decoder types **FH05B**, **FH18A** and **FH22A**.

The abbreviation **PD*** refers to decoder types **PD05A**, **PD06A**, **PD12A**, **PD18A** and **PD21A**.

CV	Name and definition	Range	Standard
01	Address (not relevant to PD*) Addresses higher than 127 are only usable in MM-operation	1-255	3
02	Starting voltage	0-15	0
03	Acceleration time The value corresponds to the time in seconds from start to maximum speed and should be set to at least 8 (see note in chapter 8.3).	0-255	3
04	Deceleration time The value corresponds to the time in seconds from the maximum speed to stop and should be set to at least 8 (see note in section 8.3).	0-255	3
05	Maximum speed (see supplement 2)	0-127	92
07	Version number (read only)		
08	Manufacturer identification (read only) 97 = Doehler & Haass (Decoder reset with "8")		
09	Motor frequency (not relevant to FH*) Bit Function Value 0.....0 = 32 kHz, 1 = 16 kHz..... 1 1.....0 = 16/32 kHz, 1 = low frequency..... 2 2.....proportional part limitation 4 3.....Switch off short circuit protection 8	0-15	1

CV	Name and definition	Range	Standard																														
12	MM settings (not relevant to PD*) Bit 0-2: 0 = MM-operation deactivated 1 = MM-operation without additional address 2 = MM-operation with one additional address 3 = MM-operation with two additional addresses 4 = MM-operation with three additional addresses 5 = MM-operation with four additional addresses 6 = MM-operation with five additional addresses 7 = MM-operation with six additional addresses Bit 3 = decoder internal use: driving direction at MM1/AC analog	0-15	1																														
13	Analog mode F1-F8 (not relevant to PD05A) <table border="0"> <thead> <tr> <th>Bit</th> <th>Function</th> <th>Value</th> <th>Bit</th> <th>Function</th> <th>Value</th> </tr> </thead> <tbody> <tr> <td>0.....</td> <td>F1</td> <td>1</td> <td>4.....</td> <td>F5</td> <td>16</td> </tr> <tr> <td>1.....</td> <td>F2</td> <td>2</td> <td>5.....</td> <td>F6</td> <td>32</td> </tr> <tr> <td>2.....</td> <td>F3</td> <td>4</td> <td>6.....</td> <td>F7</td> <td>64</td> </tr> <tr> <td>3.....</td> <td>F4</td> <td>8</td> <td>7.....</td> <td>F8</td> <td>128</td> </tr> </tbody> </table> This setting is also valid for MM1 operation.	Bit	Function	Value	Bit	Function	Value	0.....	F1	1	4.....	F5	16	1.....	F2	2	5.....	F6	32	2.....	F3	4	6.....	F7	64	3.....	F4	8	7.....	F8	128	0-255	1
Bit	Function	Value	Bit	Function	Value																												
0.....	F1	1	4.....	F5	16																												
1.....	F2	2	5.....	F6	32																												
2.....	F3	4	6.....	F7	64																												
3.....	F4	8	7.....	F8	128																												
14	Analog mode F0, F9-F12 (not relevant to PD05A) <table border="0"> <thead> <tr> <th>Bit</th> <th>Function</th> <th>Value</th> <th>Bit</th> <th>Function</th> <th>Value</th> </tr> </thead> <tbody> <tr> <td>0.....</td> <td>F0 (f)</td> <td>1</td> <td>4.....</td> <td>F11</td> <td>16</td> </tr> <tr> <td>1.....</td> <td>F0 (r)</td> <td>2</td> <td>5.....</td> <td>F12</td> <td>32</td> </tr> <tr> <td>2.....</td> <td>F9</td> <td>4</td> <td></td> <td></td> <td></td> </tr> <tr> <td>3.....</td> <td>F10</td> <td>8</td> <td></td> <td></td> <td></td> </tr> </tbody> </table> This setting is also valid for MM1 operation.	Bit	Function	Value	Bit	Function	Value	0.....	F0 (f)	1	4.....	F11	16	1.....	F0 (r)	2	5.....	F12	32	2.....	F9	4				3.....	F10	8				0-63	3
Bit	Function	Value	Bit	Function	Value																												
0.....	F0 (f)	1	4.....	F11	16																												
1.....	F0 (r)	2	5.....	F12	32																												
2.....	F9	4																															
3.....	F10	8																															

CV	Name and definition	Range	Standard																														
17	Extended address	0-255	195																														
18	CV17 contains the most significant byte; CV18 contains the least significant byte. Only, if activated by CV29/Bit 5=1.	0-255	232																														
19	Consist address Several compound locomotives run under this address (1-127) 0, 128 = deactivated Value + 128 = inverse direction	0-255	0																														
21	Consist mode F1-F8 <table border="0" style="width: 100%; border-collapse: collapse;"> <thead> <tr> <th style="text-align: left;">Bit</th> <th style="text-align: left;">Function</th> <th style="text-align: left;">Value</th> <th style="text-align: left;">Bit</th> <th style="text-align: left;">Function</th> <th style="text-align: left;">Value</th> </tr> </thead> <tbody> <tr> <td>0.....</td> <td>F1</td> <td>1</td> <td>4.....</td> <td>F5</td> <td>16</td> </tr> <tr> <td>1.....</td> <td>F2</td> <td>2</td> <td>5.....</td> <td>F6</td> <td>32</td> </tr> <tr> <td>2.....</td> <td>F3</td> <td>4</td> <td>6.....</td> <td>F7</td> <td>64</td> </tr> <tr> <td>3.....</td> <td>F4</td> <td>8</td> <td>7.....</td> <td>F8</td> <td>128</td> </tr> </tbody> </table>	Bit	Function	Value	Bit	Function	Value	0.....	F1	1	4.....	F5	16	1.....	F2	2	5.....	F6	32	2.....	F3	4	6.....	F7	64	3.....	F4	8	7.....	F8	128	0-255	0
Bit	Function	Value	Bit	Function	Value																												
0.....	F1	1	4.....	F5	16																												
1.....	F2	2	5.....	F6	32																												
2.....	F3	4	6.....	F7	64																												
3.....	F4	8	7.....	F8	128																												
22	Consist mode F0, F9-F12 <table border="0" style="width: 100%; border-collapse: collapse;"> <thead> <tr> <th style="text-align: left;">Bit</th> <th style="text-align: left;">Function</th> <th style="text-align: left;">Value</th> <th style="text-align: left;">Bit</th> <th style="text-align: left;">Function</th> <th style="text-align: left;">Value</th> </tr> </thead> <tbody> <tr> <td>0.....</td> <td>F0 (f)</td> <td>1</td> <td>4.....</td> <td>F11</td> <td>16</td> </tr> <tr> <td>1.....</td> <td>F0 (r)</td> <td>2</td> <td>5.....</td> <td>F12</td> <td>32</td> </tr> <tr> <td>2.....</td> <td>F9</td> <td>4</td> <td></td> <td></td> <td></td> </tr> <tr> <td>3.....</td> <td>F10</td> <td>8</td> <td></td> <td></td> <td></td> </tr> </tbody> </table>	Bit	Function	Value	Bit	Function	Value	0.....	F0 (f)	1	4.....	F11	16	1.....	F0 (r)	2	5.....	F12	32	2.....	F9	4				3.....	F10	8				0-63	0
Bit	Function	Value	Bit	Function	Value																												
0.....	F0 (f)	1	4.....	F11	16																												
1.....	F0 (r)	2	5.....	F12	32																												
2.....	F9	4																															
3.....	F10	8																															
27	Brake settings <table border="0" style="width: 100%; border-collapse: collapse;"> <thead> <tr> <th style="text-align: left;">Bit</th> <th style="text-align: left;">Function</th> <th style="text-align: left;">Value</th> <th style="text-align: left;">Bit</th> <th style="text-align: left;">Function</th> <th style="text-align: left;">Value</th> </tr> </thead> <tbody> <tr> <td>0.....</td> <td>Asymmetry normal</td> <td>1</td> <td>4.....</td> <td>Negative voltage</td> <td>16</td> </tr> <tr> <td>1.....</td> <td>Asymmetry inverse</td> <td>2</td> <td>5.....</td> <td>Positive voltage</td> <td>32</td> </tr> <tr> <td>2.....</td> <td>Currently without function..</td> <td>4</td> <td>6.....</td> <td>Brake diode normal</td> <td>64</td> </tr> <tr> <td>3.....</td> <td>Currently without function..</td> <td>8</td> <td>7.....</td> <td>Brake diode inverse.....</td> <td>128</td> </tr> </tbody> </table>	Bit	Function	Value	Bit	Function	Value	0.....	Asymmetry normal	1	4.....	Negative voltage	16	1.....	Asymmetry inverse	2	5.....	Positive voltage	32	2.....	Currently without function..	4	6.....	Brake diode normal	64	3.....	Currently without function..	8	7.....	Brake diode inverse.....	128	0-243	64
Bit	Function	Value	Bit	Function	Value																												
0.....	Asymmetry normal	1	4.....	Negative voltage	16																												
1.....	Asymmetry inverse	2	5.....	Positive voltage	32																												
2.....	Currently without function..	4	6.....	Brake diode normal	64																												
3.....	Currently without function..	8	7.....	Brake diode inverse.....	128																												

CV	Name and definition	Range	Standard																		
28	Check-back settings <table border="0"> <tr> <td>Bit</td> <td>Function</td> <td>Value</td> </tr> <tr> <td>0.....</td> <td>Channel 1 (Locomotive address) allowed.....</td> <td>1</td> </tr> <tr> <td>1.....</td> <td>Channel 2 (POM readout etc.) allowed</td> <td>2</td> </tr> <tr> <td>2.....</td> <td>Dynamic channel utilization</td> <td>4</td> </tr> </table>	Bit	Function	Value	0.....	Channel 1 (Locomotive address) allowed.....	1	1.....	Channel 2 (POM readout etc.) allowed	2	2.....	Dynamic channel utilization	4	0-7	3						
Bit	Function	Value																			
0.....	Channel 1 (Locomotive address) allowed.....	1																			
1.....	Channel 2 (POM readout etc.) allowed	2																			
2.....	Dynamic channel utilization	4																			
29	Configuration register <table border="0"> <tr> <td>Bit</td> <td>Function</td> <td>Value</td> </tr> <tr> <td>0.....</td> <td>Inverse direction.....</td> <td>1</td> </tr> <tr> <td>1.....</td> <td>14 ↔ 28/126 speed steps</td> <td>2</td> </tr> <tr> <td>2.....</td> <td>Analog operation allowed.....</td> <td>4 (not relevant to PD05A)</td> </tr> <tr> <td>3.....</td> <td>Check back allowed.....</td> <td>8</td> </tr> <tr> <td>5.....</td> <td>Locomotive address by CV17/18.....</td> <td>32</td> </tr> </table>	Bit	Function	Value	0.....	Inverse direction.....	1	1.....	14 ↔ 28/126 speed steps	2	2.....	Analog operation allowed.....	4 (not relevant to PD05A)	3.....	Check back allowed.....	8	5.....	Locomotive address by CV17/18.....	32	0-255	6
Bit	Function	Value																			
0.....	Inverse direction.....	1																			
1.....	14 ↔ 28/126 speed steps	2																			
2.....	Analog operation allowed.....	4 (not relevant to PD05A)																			
3.....	Check back allowed.....	8																			
5.....	Locomotive address by CV17/18.....	32																			
33	Function mapping F0(f)	(see supplement 1)	1																		
34	Function mapping F0(r)	(see supplement 1)	2																		
35	Function mapping F1(f+r) If CV35 is written, CV47 will be set to the same value	(see supplement 1)	4																		
36	Function mapping F2(f+r) If CV36 is written, CV64 will be set to the same value	(see supplement 1)	8																		
37	Function mapping F3	(see supplement 1)	16																		
38	Function mapping F4	(see supplement 1)	128																		
39	Function mapping F5	(see supplement 1)	32																		
40	Function mapping F6	(see supplement 1)	0																		
41	Function mapping F7	(see supplement 1)	0																		

CV	Name and definition	Range	Standard															
42	Function mapping F8 (see supplement 1)	0-255	64															
43	Function mapping F9 (see supplement 1)	0-255	0															
44	Function mapping F10 (see supplement 1)	0-255	0															
45	Function mapping F11 (see supplement 1)	0-255	0															
46	Function mapping F12 (see supplement 1)	0-255	0															
47	Function mapping F1 (r) (see supplement 1) In case CV47 should have a different value than CV35, you have to set CV35 first and then CV47	0-255	4															
48	Speed step characteristic (see supplement 2) Deflection of the speed step characteristic, 0 = linear ... 7 = strongly curved	0-7	5															
49	Impulse width (not relevant to FH*) 0 = 1 ms, 1 = 2 ms, 2 = 4 ms, 3 = 8 ms	0-3	1															
50	Control variant (not relevant to FH*) 0 = defined by CV56 - CV59, 1 = hard, 2 = soft, 3 = very soft	0-3	2															
51	Interchange of connections <table border="0" style="width: 100%; border-collapse: collapse;"> <thead> <tr> <th style="text-align: left;">Bit</th> <th style="text-align: left;">Function</th> <th style="text-align: left;">Value</th> </tr> </thead> <tbody> <tr> <td>0.....</td> <td>Motor connections</td> <td>1</td> </tr> <tr> <td></td> <td>(not relevant to FH05B/FH18A/FH22A)</td> <td></td> </tr> <tr> <td>1.....</td> <td>Light connections.....</td> <td>2</td> </tr> <tr> <td>2.....</td> <td>Track connections</td> <td>4</td> </tr> </tbody> </table>	Bit	Function	Value	0.....	Motor connections	1		(not relevant to FH05B/FH18A/FH22A)		1.....	Light connections.....	2	2.....	Track connections	4	0-7	0
Bit	Function	Value																
0.....	Motor connections	1																
	(not relevant to FH05B/FH18A/FH22A)																	
1.....	Light connections.....	2																
2.....	Track connections	4																

CV	Name and definition	Range	Standard
52	Dimming LV/LR 0 = dark ... 31 = full brightness	0-31	31
53	Dimming low beam light 0 = dark ... 31 = full brightness	(see CV156) 0-31	15
54	Dimming AUX1 0 = dark ... 31 = full brightness	0-31	31
55	Dimming AUX2 0 = dark ... 31 = full brightness	0-31	31
56	Motor control proportional Only if CV50 = 0, see: www.doehler-haass.de/ „Häufige Fragen“ (only in German)	(not relevant to FH*) 0-7	3
57	Motor control integral	(as CV56) 0-3	3
58	Motor control measurement period	(as CV56) 0-3	1
59	Motor control impulse width	(as CV56) 0-7	3
60	Brake sections 1 or 2	0, 1	0
61	Shuntig gear speed	(as CV05) 0-127	63
62	Shunting gear deceleration	(as CV03) 0-255	1
63	Starting delay speed step 1 Each 100 ms, 0 = deactivated	(see CV124) 0-250	0
64	Function mapping F2 (r) In case CV64 should have a different value than CV36, you must set CV36 first and then CV64	(see supplement 1) 0-255	8

CV	Name and definition	Range	Standard
65	Maximum speed step in two part brake sections Only with brake diode (see CV60)	0-127	12
66	Forward trim 0 = deactivated, smaller 128 = reduction, greater 128 = enhancement of the speed	0-255	0
95	Backward trim (see CV66)	0-255	0
105	User identification 1	0-255	0
106	User identification 2	0-255	0
112	Speed reduction analog (not relevant to FH*/PD05A) 0 = small reduction ... 31 = strong reduction	0-31	15
113	Switch off function for LV Bit 0 = F1 ... Bit 7 = F8	0-255	0
114	Switch off function for LR Bit 0 = F1 ... Bit 7 = F8	0-255	0
115	Switch off function for AUX1 Bit 0 = F1 ... Bit 7 = F8	0-255	0
116	Switch off function for AUX2 Bit 0 = F1 ... Bit 7 = F8	0-255	0
117	Timer for switch off AUX1 Each 100 ms, 0 = deactivated	0-250	0
118	Timer for switch off AUX2 Each 100 ms, 0 = deactivated	0-250	0
119	Timer for switch off AUX3 Each 100 ms, 0 = deactivated	0-250	0

CV	Name and definition	Range	Standard
120	Timer for switch off AUX4 Each 100 ms, 0 = deactivated	0-250	0
121	Function mapping LV+LR on / AUX1+AUX2 off Bit 0 = F1 ... Bit 7 = F8	0-255	0
122	Function mapping AUX1+AUX2 on / LV+LR off Bit 0 = F1 ... Bit 7 = F8	0-255	0
123	Slow approach speed Only with suitable brake modules	(see CV27) 0-127	63
124	Function mapping starting delay Bit 0 = F1 ... Bit 7 = F8	(see CV63) 0-255	0
125	Switch off function for AUX3 Bit 0 = F1 ... Bit 7 = F8	0-255	0
126	Switch off function for AUX4 Bit 0 = F1 ... Bit 7 = F8	0-255	0
127	Switch off function for AUX5 Bit 0 = F1 ... Bit 7 = F8	0-255	0
128	Switch off function for AUX6 Bit 0 = F1 ... Bit 7 = F8	0-255	0
129	Timer for switch off AUX5 Each 100 ms, 0 = deactivated	0-250	0
130	Timer for switch off AUX6 Each 100 ms, 0 = deactivated	0-250	0

CV	Name and definition	Range	Standard																														
131	Function mapping low beam light 0 = deactivated, 1 ... 28 = F1 ... F28, 29 = F0 (light) Only valid if CV137/Bit 4=1	(not relevant to PD*) 0-29	8																														
132	Function mapping shunting gear	(as CV131) 0-29	4																														
133	Function mapping deceleration off	(as CV131) 0-29	9																														
134	Decision threshold for asymmetry Default value 6 corresponds approximately to 0.7 volt asymmetry and thus to the forward voltage of a silicon diode. Values smaller 3 are not useful, values greater 6 on demand.	(see CV27) 0-15	6																														
135	Multiplication speed check back signal 0 = deactivated	0-255	0																														
136	Division speed check back signal 0 = /1, 1 = /2, 2 = /4, 3 = /8, 4 = /16, 5 = /32, 6 = /64	0-6	0																														
137	Settings <table border="0"> <thead> <tr> <th>Bit</th> <th>Function</th> <th>Value</th> </tr> </thead> <tbody> <tr> <td>0.....</td> <td>Unamplified function outputs instead of ZCLK and ZDAT *)</td> <td>1</td> </tr> <tr> <td>1.....</td> <td>Switch off energy saving mode</td> <td>2</td> </tr> <tr> <td>2.....</td> <td>Invert SUSI driving direction *)</td> <td>4</td> </tr> <tr> <td>3.....</td> <td>Currently without function *)</td> <td></td> </tr> <tr> <td>4.....</td> <td>Activate extended function mapping *)</td> <td>16</td> </tr> <tr> <td></td> <td>(see CV131 and CV137/Bit 5)</td> <td></td> </tr> <tr> <td>5.....</td> <td>0 = AUX3 and AUX4 on ZCLK and ZDAT *)</td> <td>32</td> </tr> <tr> <td></td> <td>1 = AUX5 and AUX6 on ZCLK and ZDAT *)</td> <td></td> </tr> <tr> <td></td> <td>(Only valid if CV137/Bit 0=1)</td> <td></td> </tr> </tbody> </table> <p>Explanations to Bit 0, Bit 4 and Bit 5: see end of the table *) (not relevant to PD*)</p>	Bit	Function	Value	0.....	Unamplified function outputs instead of ZCLK and ZDAT *)	1	1.....	Switch off energy saving mode	2	2.....	Invert SUSI driving direction *)	4	3.....	Currently without function *)		4.....	Activate extended function mapping *)	16		(see CV131 and CV137/Bit 5)		5.....	0 = AUX3 and AUX4 on ZCLK and ZDAT *)	32		1 = AUX5 and AUX6 on ZCLK and ZDAT *)			(Only valid if CV137/Bit 0=1)		0-63	0
Bit	Function	Value																															
0.....	Unamplified function outputs instead of ZCLK and ZDAT *)	1																															
1.....	Switch off energy saving mode	2																															
2.....	Invert SUSI driving direction *)	4																															
3.....	Currently without function *)																																
4.....	Activate extended function mapping *)	16																															
	(see CV131 and CV137/Bit 5)																																
5.....	0 = AUX3 and AUX4 on ZCLK and ZDAT *)	32																															
	1 = AUX5 and AUX6 on ZCLK and ZDAT *)																																
	(Only valid if CV137/Bit 0=1)																																

CV	Name and definition	Range	Standard
138	Timer for approach Each 100 ms, 0 = no driving away	(not relevant to PD*) 0-250	0
139	Timer for waiting Each 100 ms, 0 = no waiting	(not relevant to PD*) 0-250	0
140	Timer for driving away Each 100 ms, 0 = no driving away	(not relevant to PD*) 0-250	0
141	Speed step for approach	(not relevant to PD*) 0-127	12
142	Speed step for driving away	(not relevant to PD*) 0-127	12
143	Settings Bit Function Value 6.....Deactivate coupling process and timer 64 7.....Coupling process only in shunting gear..... 128	(not relevant to PD*) 0-255	0
144	Settings Bit Function Value 0.....Dynamic channel usage 1 1..... Immediate starting after current interruption 2 2..... Special bit for lighting in analog operation 4 3..... Brake section output to "GPIO" 8 (→ 1 = no brake section detected, 0 = braking) (only relevant to DH21A/DH22A/FH22A) 4..... Brake with "GPIO" 16 (1 = driving, 0 = braking) (only relevant to DH21A/DH22A/FH22A)	0-31	0

CV	Name and definition	Range	Standard	
145	Conditions for LV	0-161	0	
	Function			(not relevant to PD*)
				Value
	Default value (always on, if function key on)			0
	Only forward			+1
	Only backward			+2
	Only while standing			+3
	Only while driving			+6
	Only at F0 (light) off			+9
	Only at F0 (light) on			+18
	Not in shunting gear			+27
	Only in shunting gear			+54
Ignore direction in shunting gear	+81			
Ignore driving/stand in shunting gear	+108			
Ignore direction and driving/stand in shunting gear	+135			
Always only one number of each definite range may be added up!				
146	Conditions for LR	(see CV145)	0	
147	Conditions for AUX1	(see CV145)	0	
148	Conditions for AUX2	(see CV145)	0	
149	Conditions for AUX3	(see CV145)	0	
150	Conditions for AUX4	(see CV145)	0	
151	Conditions for AUX5	(see CV145)	0	
152	Conditions for AUX6	(see CV145)	0	

CV	Name and definition	Range	Standard																											
153	Initial mapping (not relevant to PD*)	0-255	0																											
	<table border="0"> <thead> <tr> <th>Bit</th> <th>Function</th> <th>Value</th> <th>Bit</th> <th>Function</th> <th>Value</th> </tr> </thead> <tbody> <tr> <td>0.....</td> <td>LV.....</td> <td>1</td> <td>4.....</td> <td>AUX3</td> <td>16</td> </tr> <tr> <td>1.....</td> <td>LR.....</td> <td>2</td> <td>5.....</td> <td>AUX4</td> <td>32</td> </tr> <tr> <td>2.....</td> <td>AUX1</td> <td>4</td> <td>6.....</td> <td>AUX5</td> <td>64</td> </tr> <tr> <td>3.....</td> <td>AUX2</td> <td>8</td> <td>7.....</td> <td>AUX6.....</td> <td>128</td> </tr> </tbody> </table> <p>These function outputs are active as soon as the decoder is addressed (without active function key). Thus, for example, the switchover of the sliding contacts can be realized in connection with the conditions.</p>			Bit	Function	Value	Bit	Function	Value	0.....	LV.....	1	4.....	AUX3	16	1.....	LR.....	2	5.....	AUX4	32	2.....	AUX1	4	6.....	AUX5	64	3.....	AUX2	8
Bit	Function	Value	Bit	Function	Value																									
0.....	LV.....	1	4.....	AUX3	16																									
1.....	LR.....	2	5.....	AUX4	32																									
2.....	AUX1	4	6.....	AUX5	64																									
3.....	AUX2	8	7.....	AUX6.....	128																									
154	Brake ramp forward and backward (see CV27, not relevant to PD05A/PD06A) Recommended for constant braking distance: CV48 = 0 0 = deactivated If maximum speed step braking time is adjusted in seconds times 8, at smaller speed steps the decoder generates the brake ramp independently	0-255	0																											
155	Brake ramp backward (see CV154) 0 = value from CV154 is used Allows different brake times forward and backward.	0-255	0																											
156	Dimming mask for low beam light (see CV53)	0-15	3																											
	<table border="0"> <thead> <tr> <th>Bit</th> <th>Function</th> <th>Value</th> <th>Bit</th> <th>Function</th> <th>Value</th> </tr> </thead> <tbody> <tr> <td>0.....</td> <td>LV.....</td> <td>1</td> <td>4.....</td> <td>Currently without function</td> <td>16</td> </tr> <tr> <td>1.....</td> <td>LR.....</td> <td>2</td> <td>5.....</td> <td>Currently without function</td> <td>32</td> </tr> <tr> <td>2.....</td> <td>AUX1</td> <td>4</td> <td>6.....</td> <td>Currently without function</td> <td>64</td> </tr> <tr> <td>3.....</td> <td>AUX2</td> <td>8</td> <td>7.....</td> <td>Currently without function</td> <td>128</td> </tr> </tbody> </table>			Bit	Function	Value	Bit	Function	Value	0.....	LV.....	1	4.....	Currently without function	16	1.....	LR.....	2	5.....	Currently without function	32	2.....	AUX1	4	6.....	Currently without function	64	3.....	AUX2	8
Bit	Function	Value	Bit	Function	Value																									
0.....	LV.....	1	4.....	Currently without function	16																									
1.....	LR.....	2	5.....	Currently without function	32																									
2.....	AUX1	4	6.....	Currently without function	64																									
3.....	AUX2	8	7.....	Currently without function	128																									
157	Conditions for low beam light (see CV145)	0-161	0																											

CV	Name and definition	Range	Standard
260	Manufacturer identification 97 = Doehler & Haass (Decoder reset with "101")	(read only)	
261	Decoder number FH05B = 41, DH05C = 52, DH10C = 102, DH12A = 120, PD12A = 130, PD05A = 131, PD06A = 132, PD21A = 133, PD18A = 134, DH14B = 141, DH16A = 160, FH18A = 170, DH18A = 180, FH22A = 192, DH21A = 200, DH22A = 202 Complete table see: www.doehler-haass.de/ „Häufige Fragen“ (only in German)	(read only)	
262	Version number	(read only)	
263	Date	(read only)	
264	Revision number	(read only)	
265	Date	(read only)	
401	Function interchange F1 0 = deactivated, 1 ... 28 = F1 ... F28, 29 = F0 (light)	(not relevant to PD*)	1
402	Function interchange F2	(as CV401)	2
403	Function interchange F3	(as CV401)	3
404	Function interchange F4	(as CV401)	4
405	Function interchange F5	(as CV401)	5
406	Function interchange F6	(as CV401)	6
407	Function interchange F7	(as CV401)	7
408	Function interchange F8	(as CV401)	8

CV	Name and definition	Range	Standard
409	Function interchange F9 (as CV401)	0-29	9
410	Function interchange F10 (as CV401)	0-29	10
411	Function interchange F11 (as CV401)	0-29	11
412	Function interchange F12 (as CV401)	0-29	12

Notes to CV137:

Activation SUSI pins: Bit 0 = 0 / Bit 4 = don't care / Bit 5 = don't care

Activation AUX3/AUX4: Bit 0 = 1 / Bit 4 = don't care / Bit 5 = 0

Activation AUX5/AUX6: Bit 0 = 1 / Bit 4 = 1 / Bit 5 = 1

8.3 Operation

Put the locomotive on the programming track and readout the locomotive address (CV01). The default value should be 3. Program the desired locomotive address and start running the locomotive keeping these setting values. After the first check you can vary the parameters of the engine freely according to your requirements.

In case your programming device indicates "Error", please check again the correct wiring of the locomotive and pay attention to the wiring instructions for connecting the programming track. **Never put such a locomotive into operation!**

Notice:

Operation with asymmetry in the brake section is not possible with the factory settings.

In case you want this option, CV27 / bit 0 and/or bit 1 must be set to "1".

Brake section operation in direct current operating mode is not possible with the factory settings.

In case you want this option, CV27 / bit 4 and/or bit 5 must be set to "1".

9 Operationsform Märklin-Motorola (MM)

9.1 Functions

Addresses.....	1 – 255
Speed steps.....	14, 28
Speed steps (internal).....	127
Front light/rear light (dimnable).....	yes
Additional functions (dimnable)	2
Functions total (only MM2).....	12
Operation with MM brake section.....	yes

Instructions for "Function Mapping" by default see: Doehler & Haass website:

<https://doehler-haass.de/cms/pages/haeufige-fragen.php>: **Wie sieht das standardmäßige „Function Mapping“ aus?**
(only in German)

Notice to address range:

In MM operation address values from 1 to 255 are allowed. In DCC operation for DCC CV01 only values from 1 to 127 are allowed. Values from 128 lead to operating the decoder only by MM, i.e. DCC operation is no longer possible. DCC "Service Mode" is still possible.

Conversely, activating the long DCC address with CV29/Bit5 means that the decoder can only be operated with DCC. Then MM operation is no longer possible and MM programming is also disabled. Attention, because "Lock out" is possible.

9.2 Programming with Märklin central unit 6020/6021

- 1 **,'Short'** programming allows entering figures between 0 and 79, i.e. in short mode just setup parameters with values from < 80 can be changed, if the desired value should also be < 80.
- 2 **,'Long'** programming allows entering figures between 0 and 255, i.e. in long mode all setup parameters with values from 0 to 255 can be changed. As the display of 6020/6021 allows only binary values, the inserting values must be divided and entered in two steps.
- 3 Programming of SUSI parameters Programming of SUSI parameters.

Please notice that 6021/6020 allows only entering values from 01 to 80. Value 0 is missing.

Instead of ,0' always ,80' must be entered.

Changing to programming mode

- The driving controller must display 0. There may not be other locomotives on the layout.
Notice the flashing signal of the locomotive!
- Push STOP and GO button of 6021 simultaneously until reset will be triggered (alternatively: disconnect for a moment the plug of the transformer). Push STOP button for disconnecting the track power.
- Enter the current decoder address. If you don't know the address, enter ,80'.

- Revert the driving direction with the driving controller (turn the driving controller to the left beyond the keystroke until you hear a click), hold the controller and push GO button.
- After about one second the lights of the engine are flashing, the decoder is now in programming mode.

Short mode

- After changing in programming mode the decoder is in short mode.
The engine lighting flashes slowly and periodically.
- Enter now the number of the CV you want to change, e.g. 01 (double digit).
- Activate the reversion of the driving direction for confirmation. Lighting is now flashing shortly two times.
- Enter now the new value for the CV, e.g. 15 (double digit).
- Activate the reversion of the driving direction for confirmation.
The lighting flashes.
- You may now enter further CV values which you want to change.

The programming mode is left by selection of CV80 or by turning off and on the track power (push STOP button and then again GO button).

Long mode

- You get the long mode by entering in short mode value 07 in CV07 at first.
The decoder confirms changing in long mode by slow flashing of the lighting.
- Enter now then hundredth and ten's digit of the CV, which you want to change.
Example: CV124 should be changed: Enter '12'.
- Activate the reversion of the driving direction for confirmation. The lighting flashes long and short (periodically).
- Enter now the unit place of the CV in double digit. See example: '04'.
- Activate the reversion of the driving direction for confirmation. The lighting flashes long - short - short (periodically).
The decoder waits now for entering the CV value.

- Enter now the hundredth and ten's digit of the new CV value.
Example: Value 135 is to be written: Enter '13'.
- Activate the reversion of the driving direction for confirmation. The lighting flashes long - short - short – short (periodically)
- Enter now the unit place of the new CV in double digit. Example: Enter '05'.
- Activate the reversion of the driving direction for confirmation.
Then the locomotive is flashing again.
- You may now enter further CVs in long mode which you want to change

The long mode can be left by switching the track voltage off and on again or by STOP.

SUSI mode

You gain the SUSI mode by writing value 09 in CV09 in short mode.

The decoder confirms that by slow flashing.

Enter CVs respective the related values as in long mode and reduce all CVs about 900.

Thus changes CV903 to 003 for example.

Notice please that you are operating in SUSI mode, which is programmed according to the long mode.

Notice:

It is easier to do the programming under DCC. Thus programmed values are also valid for MM format.

10 System format SelecTRIX 2 (SX2)

10.1 Functions

Speed steps.....	127
Speed steps (internal).....	127
Front light/rear light (dimmmable).....	yes
Additional functions (dimmmable)	2
Functions total	16
Operation with brake diodes	yes
Programming On The Main	yes

10.2 Setting options

The features of a locomotive operated in SX2 operating mode can be varied by programming the parameters (par) freels at any time. The programming procedure is described in the instructions of your programming device.

Information on the standard „Function Mapping“ can be found on the Doehler & Haass website:

<https://doehler-haass.de/cms/pages/haeufige-fragen.php>: **Wie sieht das standardmäßige „Function Mapping“ aus?**
(only in German)

10.2.1 List of supported parameters

The abbreviation **FH*** refers to the decoder types **FH05B**, **FH18A** and **FH22A**.

par	Name and definition	Range	Standard
001	Address unit position	0-99	1
002	Address hundreds digit	0-99	10
003	Address for SX1 If > 111 deactivated	0-255	112
004	Address for SX1, 1. additional channel Functions F1-F8	0-255	1
005	Address for SX1, 2. additional channel Functions F9-F16	0-255	0
006	Locomotive address output 1 = activated (if suitable occupancy detectors, power packs/boosters and central units are available).	0-1	0
007	Mode of operation additional channel 0 = relativ: 1. Additional channel = par003 + par004 2. Additional channel = par003 + par005 1 = absolute	0-1	0
008	Consist address unit place Currently without function		

par	Name and definition	Range	Standard
009	Consist address hundreds digit Currently without function		
011	Acceleration time The value corresponds to the time in seconds from start to maximum speed and should be set to at least 8 (s. notice in chapter 10.3)	0-255	3
012	Deceleration time The value corresponds to the time in seconds from the maximum speed to stop and should be set to at least 8 (s. notice in chapter 10.3)	0-255	3
013	Maximum speed (see supplement 2)	0-127	92
014	Starting voltage	0-15	0
015	Slow approach speed step (see par091) Only with suitable brake modules	0-127	63
016	Start delay speed step 1 (see par095) Each 100 ms, 0 = deactivated	0-250	0
017	Speed reduction analog (not relevant to FH*/PD05A) 0 = small reduction ... 31 = strong reduction	0-31	15
018	Shunting gear speed (as par013)	0-127	63
019	Shunting gear delay time (as par011)	0-255	1
021	Brake sections 1 or 2	0, 1	0
022	Consist mode F1-F8 Currently without function		

par	Name and definition	Range	Standard																														
023	Consist mode F0, F9-F12 Currently without function																																
024	Switch off function for LV Bit 0 = F1 ... Bit 7 = F8	0-255	0																														
025	Switch off function for LR Bit 0 = F1 ... Bit 7 = F8	0-255	0																														
026	Switch off function for AUX1 Bit 0 = F1 ... Bit 7 = F8	0-255	0																														
027	Switch off function for AUX2 Bit 0 = F1 ... Bit 7 = F8	0-255	0																														
028	Analog mode F1-F8 <table border="0" style="width: 100%; border-collapse: collapse;"> <thead> <tr> <th style="text-align: left;">Bit</th> <th style="text-align: left;">Function</th> <th style="text-align: left;">Value</th> <th style="text-align: left;">Bit</th> <th style="text-align: left;">Function</th> <th style="text-align: left;">Value</th> </tr> </thead> <tbody> <tr> <td>0.....</td> <td>F1.....</td> <td>1</td> <td>4.....</td> <td>F5.....</td> <td>16</td> </tr> <tr> <td>1.....</td> <td>F2.....</td> <td>2</td> <td>5.....</td> <td>F6.....</td> <td>32</td> </tr> <tr> <td>2.....</td> <td>F3.....</td> <td>4</td> <td>6.....</td> <td>F7.....</td> <td>64</td> </tr> <tr> <td>3.....</td> <td>F4.....</td> <td>8</td> <td>7.....</td> <td>F8.....</td> <td>128</td> </tr> </tbody> </table>	Bit	Function	Value	Bit	Function	Value	0.....	F1.....	1	4.....	F5.....	16	1.....	F2.....	2	5.....	F6.....	32	2.....	F3.....	4	6.....	F7.....	64	3.....	F4.....	8	7.....	F8.....	128	0-255	1
Bit	Function	Value	Bit	Function	Value																												
0.....	F1.....	1	4.....	F5.....	16																												
1.....	F2.....	2	5.....	F6.....	32																												
2.....	F3.....	4	6.....	F7.....	64																												
3.....	F4.....	8	7.....	F8.....	128																												
029	Analog mode F0, F9-F12 <table border="0" style="width: 100%; border-collapse: collapse;"> <thead> <tr> <th style="text-align: left;">Bit</th> <th style="text-align: left;">Function</th> <th style="text-align: left;">Value</th> <th style="text-align: left;">Bit</th> <th style="text-align: left;">Function</th> <th style="text-align: left;">Value</th> </tr> </thead> <tbody> <tr> <td>0.....</td> <td>F0 (f).....</td> <td>1</td> <td>4.....</td> <td>F11.....</td> <td>16</td> </tr> <tr> <td>1.....</td> <td>F0 (r).....</td> <td>2</td> <td>5.....</td> <td>F12.....</td> <td>32</td> </tr> <tr> <td>2.....</td> <td>F9.....</td> <td>4</td> <td></td> <td></td> <td></td> </tr> <tr> <td>3.....</td> <td>F10.....</td> <td>8</td> <td></td> <td></td> <td></td> </tr> </tbody> </table>	Bit	Function	Value	Bit	Function	Value	0.....	F0 (f).....	1	4.....	F11.....	16	1.....	F0 (r).....	2	5.....	F12.....	32	2.....	F9.....	4				3.....	F10.....	8				0-63	3
Bit	Function	Value	Bit	Function	Value																												
0.....	F0 (f).....	1	4.....	F11.....	16																												
1.....	F0 (r).....	2	5.....	F12.....	32																												
2.....	F9.....	4																															
3.....	F10.....	8																															
031	Interchange of track connections 0 = normal, 1 = interchanged	0, 1	0																														

par	Name and definition	Range	Standard																								
032	Interchange of motor connections 0 = normal, 1 = interchanged (not relevant to FH*)	0, 1	0																								
033	Interchange of light connections 0 = normal, 1 = interchanged	0, 1	0																								
043	Settings <table border="0" style="width: 100%; border-collapse: collapse;"> <thead> <tr> <th style="text-align: left;">Bit</th> <th style="text-align: left;">Function</th> <th style="text-align: left;">Value</th> </tr> </thead> <tbody> <tr> <td>0.....</td> <td>Dynamic channel usage (not relevant to SX1/SX2)</td> <td>1</td> </tr> <tr> <td>1.....</td> <td>Immediate starting after current interruption.....</td> <td>2</td> </tr> <tr> <td>2.....</td> <td>Special bit for lighting in analog operation.....</td> <td>4</td> </tr> <tr> <td>3.....</td> <td>Brake section output to "GPIO"</td> <td>8</td> </tr> <tr> <td></td> <td>(→ 1 = no brake section detected, 0 = braking) (not relevant to DH21A/DH22A/FH22A)</td> <td></td> </tr> <tr> <td>4.....</td> <td>Brake with "GPIO" (1 = driving, 0 = braking)</td> <td>16</td> </tr> <tr> <td></td> <td>(only relevant to DH21A/DH22A/FH22A)</td> <td></td> </tr> </tbody> </table>	Bit	Function	Value	0.....	Dynamic channel usage (not relevant to SX1/SX2)	1	1.....	Immediate starting after current interruption.....	2	2.....	Special bit for lighting in analog operation.....	4	3.....	Brake section output to "GPIO"	8		(→ 1 = no brake section detected, 0 = braking) (not relevant to DH21A/DH22A/FH22A)		4.....	Brake with "GPIO" (1 = driving, 0 = braking)	16		(only relevant to DH21A/DH22A/FH22A)		0-31	0
Bit	Function	Value																									
0.....	Dynamic channel usage (not relevant to SX1/SX2)	1																									
1.....	Immediate starting after current interruption.....	2																									
2.....	Special bit for lighting in analog operation.....	4																									
3.....	Brake section output to "GPIO"	8																									
	(→ 1 = no brake section detected, 0 = braking) (not relevant to DH21A/DH22A/FH22A)																										
4.....	Brake with "GPIO" (1 = driving, 0 = braking)	16																									
	(only relevant to DH21A/DH22A/FH22A)																										
051	Speed step characteristic Deflection of the characteristic curve, 0 = linear ... 7 = strongly curved (see supplement 2)	0-7	5																								
052	Control variant 0 = defined by par056 ff, 1 = hard, 2 = soft, 3 = very soft (not relevant to FH*)	0-3	2																								
053	Impulse width 0 = 1 ms, 1 = 2 ms, 2 = 4 ms, 3 = 8 ms (not relevant to FH*)	0-3	1																								

par	Name and definition	Range	Standard
054	Motor frequency (not relevant to FH*)	0-15	1
	Bit Function Value		
	0.....0 = 32 kHz, 1 = 16 kHz..... 1		
	1.....0 = 16/32 kHz, 1 = low frequency..... 2		
	2.....proportional part limitation..... 4		
3.....Switch off short circuit protection..... 8			
055	Maximum speed step in two part brake sections (see par021) Only with brake diode	0-127	12
056	Motor control proportional (not relevant to FH*) Only if par052 = 0, see: www.doehler-haass.de/ „Häufige Fragen“ (only in German)	0-7	3
057	Motor control integral (as par056)	0-3	3
058	Motor control measurement period (as par056)	0-3	1
059	Motor control impulse width (as par056)	0-7	3
061	Function mapping F0(f) (see supplement 1)	0-255	1
062	Function mapping F0(r) (see supplement 1)	0-255	2
063	Function mapping F1(f+r) (see supplement 1) If par063 is written, par075 will be set to the same value	0-255	4
064	Function mapping F2(f+r) (see supplement 1) If par064 is written, par085 will be set to the same value	0-255	8
065	Function mapping F3 (see supplement 1)	0-255	16
066	Function mapping F4 (see supplement 1)	0-255	128
067	Function mapping F5 (see supplement 1)	0-255	32

par	Name and definition	Range	Standard
068	Function mapping F6 (see supplement 1)	0-255	0
069	Function mapping F7 (see supplement 1)	0-255	0
070	Function mapping F8 (see supplement 1)	0-255	64
071	Function mapping F9 (see supplement 1)	0-255	0
072	Function mapping F10 (see supplement 1)	0-255	0
073	Function mapping F11 (see supplement 1)	0-255	0
074	Function mapping F12 (see supplement 1)	0-255	0
075	Function mapping F1(r) (see supplement 1) In case par075 should have a different value than par063, you must set par063 first and then par075	0-255	4
076	Timer for switch off AUX1 Each 100 ms, 0 = deactivated	0-250	0
077	Timer for switch off AUX2 Each 100 ms, 0 = deactivated	0-250	0
078	Timer for switch off AUX3 Each 100 ms, 0 = deactivated	0-250	0
079	Timer for switch off AUX4 Each 100 ms, 0 = deactivated	0-250	0
081	Dimming LV/LR 0 = dark ... 31 = full brightness	0-31	31
082	Dimming low beam light 0 = dark ... 31 = full brightness (see par089)	0-31	15

par	Name and definition	Range	Standard																														
083	Dimming AUX1 0 = dark ... 31 = full brightness	0-31	31																														
084	Dimming AUX2 0 = dark ... 31 = full brightness	0-31	31																														
085	Function mapping F2(r) (see supplement 1) In case par085 should have a different value than par064, you must set par064 first and then par085	0-255	8																														
086	Function mapping LV+LR on / AUX1+AUX2 off Bit 0 = F1 ... Bit 7 = F8	0-255	0																														
087	Function mapping AUX1+AUX2 on / LV+LR off Bit 0 = F1 ... Bit 7 = F8	0-255	0																														
088	Settings <table border="0"> <thead> <tr> <th>Bit</th> <th>Function</th> <th>Value</th> </tr> </thead> <tbody> <tr> <td>0.....</td> <td>Unamplified function outputs instead of ZCLK and ZDAT *)</td> <td>1</td> </tr> <tr> <td>1.....</td> <td>Switch off energy saving mode.....</td> <td>2</td> </tr> <tr> <td>2.....</td> <td>Invert SUSI driving direction *).....</td> <td>4</td> </tr> <tr> <td>3.....</td> <td>Switch off SUSI starting delay *).....</td> <td>8</td> </tr> <tr> <td>4.....</td> <td>Activate extended function mapping *).....</td> <td>16</td> </tr> <tr> <td colspan="3">(see par088/Bit 5 and par147)</td> </tr> <tr> <td>5.....</td> <td>0 = AUX3 and AUX4 on ZCLK and ZDAT *).....</td> <td>32</td> </tr> <tr> <td></td> <td>1 = AUX5 and AUX6 on ZCLK and ZDAT *)</td> <td></td> </tr> <tr> <td colspan="3">(only valid if par088/Bit 0=1)</td> </tr> </tbody> </table> <p>Explanations to bit 0, bit 4 and bit 5: see end of the table *) not relevant to PD05A / PD06A</p>	Bit	Function	Value	0.....	Unamplified function outputs instead of ZCLK and ZDAT *)	1	1.....	Switch off energy saving mode.....	2	2.....	Invert SUSI driving direction *).....	4	3.....	Switch off SUSI starting delay *).....	8	4.....	Activate extended function mapping *).....	16	(see par088/Bit 5 and par147)			5.....	0 = AUX3 and AUX4 on ZCLK and ZDAT *).....	32		1 = AUX5 and AUX6 on ZCLK and ZDAT *)		(only valid if par088/Bit 0=1)			0-63	0
Bit	Function	Value																															
0.....	Unamplified function outputs instead of ZCLK and ZDAT *)	1																															
1.....	Switch off energy saving mode.....	2																															
2.....	Invert SUSI driving direction *).....	4																															
3.....	Switch off SUSI starting delay *).....	8																															
4.....	Activate extended function mapping *).....	16																															
(see par088/Bit 5 and par147)																																	
5.....	0 = AUX3 and AUX4 on ZCLK and ZDAT *).....	32																															
	1 = AUX5 and AUX6 on ZCLK and ZDAT *)																																
(only valid if par088/Bit 0=1)																																	

par	Name and definition						Range	Standard
089	Dimming mask for low beam light (see par082)						0-15	3
	Bit	Function	Value	Bit	Function	Value		
	0.....	LV	1	4.....	Currently without function	16		
	1.....	LR.....	2	5.....	Currently without function	32		
	2.....	AUX1	4	6.....	Currently without function	64		
3.....	AUX2	8	7.....	Currently without function ..	128			
091	Brake settings						0-255	64
	Bit	Function	Value	Bit	Function	Value		
	0.....	Asymmetry normal.....	1	4	Negative voltage	16		
	1.....	Asymmetry invers.....	2	5	Positive voltage.....	32		
	2.....	Currently without function ..	4	6	Brake diode normal	64		
3.....	Currently without function ..	8	7	Brake diode inverse	128			
092	Decision threshold for asymmetry (see par091)						0-15	6
	Default value 6 corresponds approximately to 0.7 volt asymmetry and thus to the forward voltage of a silicon diode. Values smaller 3 are not useful, values greater 6 on demand.							
093	Forward trim						0-255	0
	0 = deactivated, smaller 128 = reduction, greater 128 = increasing speed							
094	Backward trim (see par093)						0-255	0
095	Function mapping starting delay (see par016)						0-255	0
	Bit 0 = F1 ... Bit 7 = F8							

par	Name and definition	Range	Standard
096	Brake ramp forward and backward (see par091, not relevant to PD05A/PD06A) Recommended for constant braking distance: par051 = 0 0 = deactivated If maximum speed step braking time is adjusted in seconds 8 times, at smaller speed steps the decoder generates the brake ramp independently	0-255	0
097	Brake ramp backward (see par096) 0 = value from CV154 is used Allows different brake times forward and backward	0-255	0
098	User identification 1	0-255	0
099	User identification 2	0-255	0
101	Manufacturer number (read only) 97 = Doehler & Haass (Decoder reset with "101")		
102	Decoder number (read only) FH05B = 41, DH05C = 52, DH10C = 102, DH12A = 120, PD12A = 130, PD05A = 131, PD06A = 132, PD21A = 133, PD18A = 134, DH14B = 141, DH16A = 160, FH18A = 170, DH18A = 180, FH22A = 192, DH21A = 200, DH22A = 202 Complete table see: www.doehler-haass.de/ „Häufige Fragen“ (only in German)		
103	Version number (read only)		
104	Date (read only)		
105	Revision number (read only)		
106	Date (read only)		
141	Switch off function for AUX3 Bit 0 = F1 ... Bit 7 = F8	0-255	0

par	Name and definition	Range	Standard
142	Switch off function for AUX4 Bit 0 = F1 ... Bit 7 = F8	0-255	0
143	Switch off function for AUX5 Bit 0 = F1 ... Bit 7 = F8	0-255	0
144	Switch off function for AUX6 Bit 0 = F1 ... Bit 7 = F8	0-255	0
145	Timer for switch off AUX5 Each 100 ms, 0 = deactivated	0-250	0
146	Timer for switch off AUX6 Each 100 ms, 0 = deactivated	0-250	0
147	Function mapping low beam light (not relevant to PD05A/PD06A) 0 = deactivated, 1 ... 28 = F1 ... F28, 29 = F0 (light) Only valid if par088/Bit 4=1	0-29	8
148	Function mapping shunting gear (as par147)	0-29	4
149	Function mapping deceleration off (as par147)	0-29	9
151	Timer for approach (not relevant to PD05A/PD06A) Each 100 ms, 0 = no approach	0-250	0
152	Timer for waiting (not relevant to PD05A/PD06A) Each 100 ms, 0 = no waiting	0-250	0
153	Timer für driving away (not relevant to PD05A/PD06A) Each 100 ms, 0 = no driving away	0-250	0
154	Speed steps for approach (not relevant to PD05A/PD06A)	0-127	12
155	Speed steps for driving away (not relevant to PD05A/PD06A)	0-127	12

par	Name and definition	Range	Standard
156	Settings (not relevant to PD05A/PD06A)	0-255	0
	Bit Function Value		
	6.....Coupling process and timer deactivated.....64 7.....Coupling process only in shunting gear..... 128		
160	Conditions for low beam light (see par161)	0-161	0
161	Conditions for LV (not relevant to PD05A/PD06A)	0-161	0
	Function Value		
	Initial state (always on, if function key on) 0		
	Only forward +1		
	Only backward +2		
	Only while standing +3		
	Only while driving +6		
	Only at F0 (light) off +9		
	Only at F0 (light) on +18		
	Not in shunting gear +27		
	Only in shunting gear +54		
	Ignore direction in shunting gear +81		
	Ignore driving/stand in shunting gear +108		
Ignore direction and driving/stand in shunting gear +135			
Always only one number of each definite range may be added up!			
162	Conditions for LR (see par161)	0-161	0
163	Conditions for AUX1 (see par161)	0-161	0
164	Conditions for AUX2 (see par161)	0-161	0
165	Conditions for AUX3 (see par161)	0-161	0

par	Name and definition	Range	Standard																														
166	Conditions for AUX4 (see par161)	0-250	0																														
167	Conditions for AUX5 (see par161)	0-127	0																														
168	Conditions for AUX6 (see par161)	0-127	0																														
169	Initial mapping (not relevant to PD05A/PD06A) <table border="0" style="width: 100%; border-collapse: collapse;"> <thead> <tr> <th style="text-align: left;">Bit</th> <th style="text-align: left;">Function</th> <th style="text-align: left;">Value</th> <th style="text-align: left;">Bit</th> <th style="text-align: left;">Function</th> <th style="text-align: left;">Value</th> </tr> </thead> <tbody> <tr> <td>0.....</td> <td>LV</td> <td>1</td> <td>4.....</td> <td>AUX3.....</td> <td>16</td> </tr> <tr> <td>1.....</td> <td>LR.....</td> <td>2</td> <td>5.....</td> <td>AUX4.....</td> <td>32</td> </tr> <tr> <td>2.....</td> <td>AUX1</td> <td>4</td> <td>6.....</td> <td>AUX5.....</td> <td>64</td> </tr> <tr> <td>3.....</td> <td>AUX2</td> <td>8</td> <td>7.....</td> <td>AUX6.....</td> <td>128</td> </tr> </tbody> </table> <p>These function outputs are active as soon as the decoder is addressed (without active function key). Thus, for example, the switchover of the sliding contacts can be realized, in connection with the conditions.</p>	Bit	Function	Value	Bit	Function	Value	0.....	LV	1	4.....	AUX3.....	16	1.....	LR.....	2	5.....	AUX4.....	32	2.....	AUX1	4	6.....	AUX5.....	64	3.....	AUX2	8	7.....	AUX6.....	128	0-255	0
Bit	Function	Value	Bit	Function	Value																												
0.....	LV	1	4.....	AUX3.....	16																												
1.....	LR.....	2	5.....	AUX4.....	32																												
2.....	AUX1	4	6.....	AUX5.....	64																												
3.....	AUX2	8	7.....	AUX6.....	128																												
401	Function interchange F1 0 = deactivated, 1 ... 28 = F1 ... F28, 29 = F0 (light)	0-29	1																														
402	Function interchange F2 (as par401)	0-29	2																														
403	Function interchange F3 (as par401)	0-29	3																														
404	Function interchange F4 (as par401)	0-29	4																														
405	Function interchange F5 (as par401)	0-29	5																														
406	Function interchange F6 (as par401)	0-29	6																														
407	Function interchange F7 (as par401)	0-29	7																														
408	Function interchange F8 (as par401)	0-29	8																														
409	Function interchange F9 (as par401)	0-29	9																														

par	Name and definition	Range	Standard
410	Function interchange F10 (as par401)	0-29	10
411	Function interchange F11 (as par401)	0-29	11
412	Function interchange F12 (as par401)	0-29	12

Notes to par088:

Activation SUSI pins: Bit 0 = 0 / Bit 4 = don't care / Bit 5 = don't care

Activation AUX3/AUX4: Bit 0 = 1 / Bit 4 = don't care / Bit 5 = 0

Activation AUX5/AUX6: Bit 0 = 1 / Bit 4 = 1 / Bit 5 = 1

10.3 Operation

Put the locomotive on the programming track and readout the locomotive address of the decoder (par001+par002). The ground value should be 1001. Program the desired locomotive address and start running the locomotive keeping these parameter values. After the first check you can vary the parameters of the engine freely according to your requirements.

In case your programming device indicates "Error", please check again the correct wiring of the locomotive and pay attention to the wiring instructions for connecting the programming track. **Never put such a locomotive into operation!**

Supplement 1: Notes to Function Mapping

If you want to activate a function enter the value of the corresponding output according to the following table. In case you want to activate several different functions simultaneously you must add up the related values.

Output values:

	RG/AUX6	ABL/AUX5	AUX4	AUX3	AUX2	AUX1	LR	LV
Value	128	64	32	16	8	4	2	1

RG = shunting gear ABL = low beam light

Example: F4 should activate the shunting gear and switch on the outputs LV and LR:
LV=1, LR=2, RG=128: so you must enter the value 131 in CV38 | par066.

Notice: AUX3 and AUX4 are not available in all decoders as amplified ones, however always alternatively available to ZCLK and ZDAT as unamplified ones.

AUX5 and AUX6 are not in all decoders available (generally only unamplified), however always alternatively available to ZCLK and ZDAT as unamplified ones.

Timer function (CV117-120, 129, 130, par076-079, 145, 146)

Value = 0 The timer is switched off (continuous function)

Value = 1...250 The timer is activated, the corresponding output will be disconnected after the time of:
entered value x 0.1 [sec].

Switch off function (CV113-116, CV125-128, par024-027, par141-par144)

This function gives you the option for deactivating the output (e.g. frontal driving cab light off), despite of activated output (e.g. LV by function F0).

Example:

A typical situation where to apply the switch off function is the push pull operation.

The front lightning pointing to the waggon must be switched off, but the other lights must be reversed according to the driving direction (white ↔ red).

F0 Switches the light on (white or red according to the driving direction)

F2 Switches the font light off

F3 Switches the rear lighth off

CV	par	Function	RG	ABL	AUX4	AUX3	AUX2	AUX1	LR	LV
33	061	F0(f)					X			X
34	062	F0(r)						X	X	

CV	par	Function	F8	F7	F6	F5	F4	F3	F2	F1
113	024	LV off							X	
114	025	LR off						X		
115	026	AUX1 off							X	
116	027	AUX2 off						X		

LV Front light white

AUX1 Front light red

LR Rear light white

AUX2 Rear light red

Supplement 2: Speed characteristics

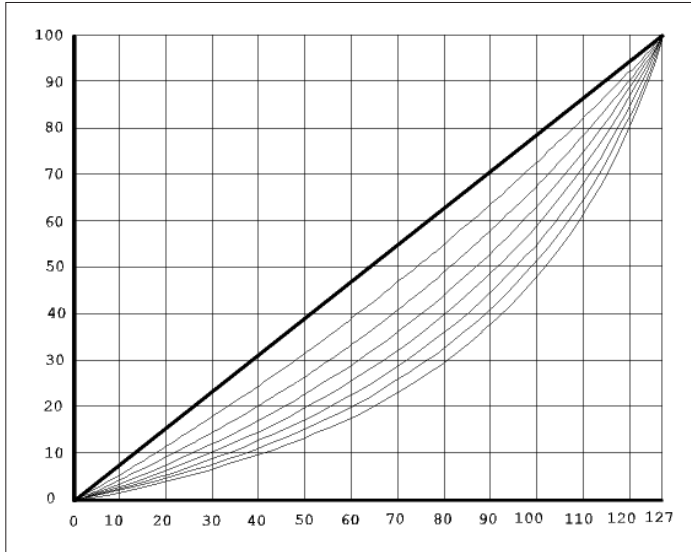

Speed step characteristic *),
(see CV48 / par051)

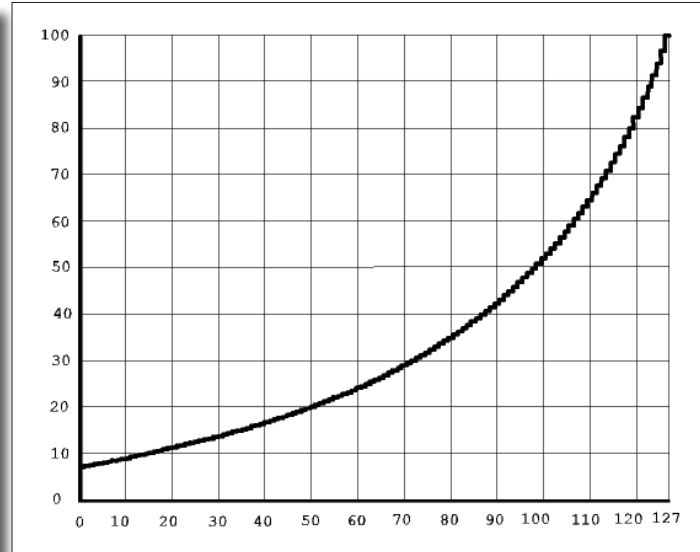

Maximum speed characteristic
(see CV05 / par013)

Linear..... 0
Strongly curved..... 7

*) The curvature of the speed step characteristic corresponds with the DHL locomotive decoder series.

Supplement 3: Unamplified function outputs AUX3 ... AUX6

As in case the unamplified function outputs AUX3 ... AUX6 (logic level 0 V - 5 V, max. 20 mA) cannot switch greater loads, switching amplifiers (MOSFET, bipolar transistors or the like) must be provided for consumers, which either require a higher supply voltage (> 5 V) or a higher current (> 20 mA).

Supplement 4: Electric coupling / Freewheeling diode

Electric couplings – i.e. couplings, which can automatically uncouple remotely – are magnetic articles and therefore inductive consumers.

When switching off the current they may generate by the coil of the magnetic product a high voltage with opposite polarity (up to several hundred volts) by self induction. By exceeding the maximum cut off voltage of the function outputs of the most sensitive MOSFET output drivers, they can be destroyed irreparably!

It is therefore imperative to close shortly these voltages by freewheeling diodes:

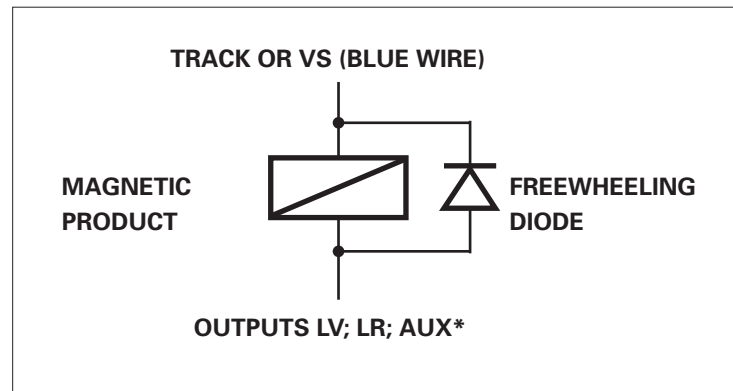

Please make sure that the function output you have chosen for connecting the electric coupling has a sufficiently high capacity! We recommend the connections AUX3 and AUX4 of our decoders, which are designed for currents up to 1 A.

Hint:

Use the coupling functions of our decoders (timer for switching off AUX*) to make sure that the function output will be switched off in any case according to a maximum activation time specified by you. Otherwise the destruction of the electric coupling is possible.

Refer to supplement 5.

Supplement 5: Automatic coupling procedure (“coupling waltz”)

Principle function

If a locomotive with attached wagon train has been driven into the station in forward driving and now the wagon train should be uncoupled, the locomotive must approach the wagon train backwards to relieve the coupling. Then the coupling must be activated by relaxed towing hook. Now the locomotive is driving away with activated coupling a bit, until the coupling is in rest position.

“Coupling waltz” is not assigned to a function; it is automatically available, as long as it is activated by CV143 Bit 6 = 0.

The time procedure is defined by CVs (see chart):

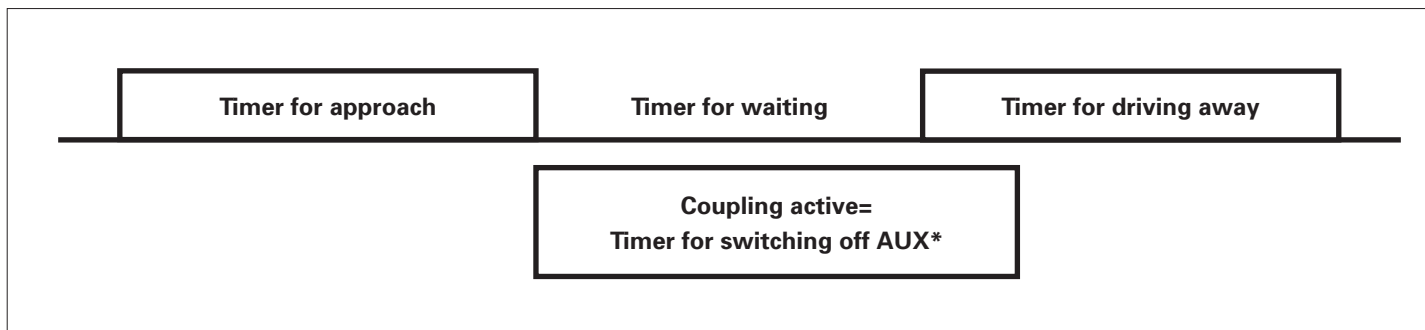

CV138 Timer for approach

CV139 Timer for waiting

CV140 Timer for driving away

Using the coupling function of our decoder it must be ensured that the function output will be switched off in any case according to a maximum activation time specified by you. Otherwise the destruction of the electric coupling is possible.

The time, while coupling is activated, is defined by the switching off function:

CV117 Timer for switching off AUX1

CV118 Timer for switching off AUX2

CV119 Timer for switching off AUX3

CV120 Timer for switching off AUX4

CV129 Timer for switching off AUX5

CV130 Timer for switching off AUX6

Please proceed as follows:

For function output AUX1 please use CV 117 (par076)

For function output AUX2 please use CV 118 (par077)

For function output AUX3 please use CV 119 (par078)

For function output AUX4 please use CV 120 (par079)

For function output AUX5 please use CV 129 (par145)

For function output AUX6 please use CV 130 (par146)

The adjusted value is internal multiplied by 100 milliseconds. If you want for example to achieve a maximum activation time of one second, please program the value 10.

Value 0 means no coupling function.

That a coupling waltz should be executed the decoder recognizes by the fact that a value unevenly 0 is entered at different times.

Operating the couplings with 2 function keys

Should the couplings be connected for example to AUX3 (in front) and AUX4 (at the rear), times are to be entered at AUX3 and AUX4. The mapping of the function keys (which function key should control which coupling), is set by the normale function mapping (see next page).

For example F3 = AUX3 and F4 = AUX4 should be assigned:

CV37 Function mapping F3 (in the example = 16 for AUX3)

CV38 Function mapping F4 (in the example = 32 for AUX4)

Operating the couplings with 1 function key

Should the couplings be connected for example to AUX3 (in front) and AUX4 (at the rear), times are to be entered at AUX3 and AUX4. The corresponding function key must now be assigned to both couplings.

For example shall F4 = AUX3 and AUX4 operate:

CV38 Function mapping F4 (in example = $16 + 32 = 48$ for AUX3 + AUX4)

Which coupling should react must be defined by a condition.

In the example AUX3 should that be for forward and AUX4 for backward:

CV149 Condition for AUX3: forward only = 1

CV150 Condition for AUX4: backward only = 2

Notes to function mapping

If you want to activate a function enter the value of the corresponding output according to the following table. In case you want to activate several different functions simultaneously you must add up the related values.

Outputs values:

	RG/AUX6	ABL/AUX5	AUX4	AUX3	AUX2	AUX1	LR	LV
Value	128	64	32	16	8	4	2	1

RG = shunting gear ABL = low beam light

Supplement 6: Decoder detection

Which decoder is it?

Please read out the CV261. You can determine the decoder by the read out value with the help of the listing of the CV261 in the CV table of this description.

How do I recognize the firmware version of the decoder?

Please read out the CV264. The read out value must be at least as big as the value after the dot in the above firmware version bar next to our logo.

If this should not be the case, an older description is required for your decoder.

Märklin®

is a registered trademark of the company Gebr. Märklin & Cie. GmbH, D-73033 Göppingen

Motorola®

is a registered trademark of the company Motorola Inc., Schaumburg, Illinois, USA

RailCom®

is a registered trademark of the company Lenz Elektronik GmbH, D-35398 Gießen

SelecTRIX®

is a registered trademark of the company Gebr. Märklin & Cie. GmbH, D-73033 Göppingen

Super-Soft-Drive (SSD)®

is a registered trademark of the company Doehler & Haass GmbH & Co. KG, D-81249 München

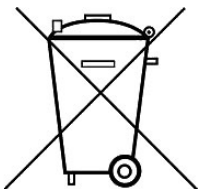

Dieses Produkt darf am Ende seiner Nutzungsdauer nicht über den normalen Hausmüll entsorgt werden. Bitte benutzen Sie die Entsorgungsstelle Ihrer Gemeinde.

This product must not be disposed of with normal household waste at the end of its useful life. Please use the disposal point in your municipality.

Ce produit ne doit pas être éliminé avec les déchets ménagers normaux à la fin de sa vie utile. Veuillez utiliser le point d'élimination de votre autorité locale.



Nicht geeignet für Kinder unter 3 Jahren wegen der Gefahr des Verschluckens sowie der Verletzung durch scharfkantige Teile!

Not suitable for children under 36 month because of the danger of swallowing the product and of injuries due to sharp-edged parts.

Ne convient pas aux enfants au-dessous de 3 ans, dus au risque d'avalier le produit ou bien d'être blessés par des pièces à arêtes vives!



Company Stamp

Doehler & Haass Steuerungssysteme GmbH & Co. KG

c/o Frau Barbara Karpati
Ludwig-Braille-Straße 3
D-81379 Muenchen
Tel. +49 (0)89 13 93 72 21
technik@doehler-haass.de
www.doehler-haass.de

© 2020 Doehler & Haass
Changes and errors reserved

Edition 07/2020